



GESC MANUAL



May 2018

Revised:
May 2019
February
2023

Grading, Erosion and Sediment Control Requirements

Contents

1	THE GESC PERMIT PROGRAM.....	5
1.1	INTERPRETATION AND APPLICATION	5
1.4	STATE AND FEDERAL PERMITTING.....	7
	STATE PERMITTING	7
	FEDERAL PERMITTING.....	7
1.6	AMENDMENTS AND REVISIONS.....	8
1.7	ENFORCEMENT RESPONSIBILITY.....	8
1.8	SPECIAL CONSIDERATIONS FOR CO-REGULATING MS4 PERMITTEES.....	8
2	GESC PERMIT PROCESS CONSIDERATIONS.....	9
2.1	WHEN A GESC PERMIT IS REQUIRED	9
2.2	PROJECTS COVERED UNDER OTHER PERMITS AND/OR PLAN	9
2.3	GESC PERMIT RESPONSIBILITY.....	9
2.4	REVIEW AND ACCEPTANCE LIMITATIONS.....	10
2.5	PLAN AND REPORT AMENDMENT PROTOCOLS.....	10
2.6	WATER CONTROL PLAN REVIEW.....	10
2.7	A GESC PLAN IS NOT A SWMP.....	10
3	TYPES OF GESC PERMITS	12
3.1	STANDARD GESC PERMIT	12
3.2	LOW IMPACT GESC PERMIT	14
3.3	SINGLE-FAMILY INDIVIDUAL LOT GESC PERMIT	15
3.4	ANNUAL GESC PERMIT.....	16
3.5	LOW RISK GESC PROTOCOLS.....	17
4	GESC PERMIT POLICIES.....	18
4.1	APPROVED GESC PLAN AND REPORT.....	18
4.2	GESC PERMIT EXPIRATION	18
4.3	GESC PERMITS WITH PROPERTY OR PROJECT OWNERSHIP TRANSFERS.....	18
4.4	RESPONSIBILITIES FOR SINGLE-FAMILY RESIDENTIAL PROJECTS.....	19
4.5	GESC PERMITTEE SELLS A PORTION OF THE LAND/PROJECT AREA TO A BUILDER	19
4.6	REVIEW FEE PAYMENT	19
4.7	CONSISTENCY WITH OTHER PLANS.....	20
4.8	EARLY GRADING PERMIT REQUIREMENTS.....	20

4.9 PERMIT FEE PAYMENT	20
4.10 ENGINEERING COST ESTIMATES	20
4.11 COLLATERAL POSTING.....	20
4.12 VARIANCES TO THE GESC MANUAL	22
5 GESC PERMIT CLOSE-OUT.....	24
5.1 INITIAL CLOSE-OUT	24
5.2 REQUIRED INSPECTIONS AND MAINTENANCE AFTER INITIAL CLOSE-OUT	24
5.3 FINAL VEGETATION ACCEPTANCE.....	24
5.4 REMOVAL OF FINAL STABILIZATION CONTROL MEASURES.....	25
5.5 FINAL CLOSE-OUT INSPECTION	25
6 ENFORCEMENT.....	26
6.1 NONCOMPLIANCE.....	26
6.2 RIGHT TO COMPLETE GESC CONTROL MEASURES	27
6.3 USE OF FUNDS.....	27
7 FIELD POLICIES.....	28
7.1 RESPONSIBILITIES OF THE GESC MANAGER.....	28
7.2 AVAILABILITY OF THE GESC MANAGER.....	28
7.3 CHANGING THE GESC MANAGER OR ALTERNATE	28
7.4 DOCUMENTS THAT SHALL REMAIN ON SITE.....	28
7.5 PRECONSTRUCTION MEETING	28
7.6 TOPSOIL PRESERVATION	29
7.7 STABILIZATION	29
7.8 INSTALLATION OF INTERIM AND FINAL CONTROL MEASURES.....	29
8 REQUIRED GESC INSPECTIONS	29
8.1 GESC INSPECTIONS CONDUCTED BY GESC PERMIT HOLDER.....	29
8.2 GESC INSPECTIONS CONDUCTED BY SEMSWA	29
9 SITE GRADING DESIGN GUIDANCE AND CRITERIA	30
9.1 SLOPES.....	30
9.2 STOCKPILES	30
10 GENERAL CONSTRUCTION PRACTICES	31
10.1 LIMITS OF CONSTRUCTION	31
10.2 STREET CLEANING	31
10.3 DUST CONTROL.....	31
10.4 CONSTRUCTION SITE WASTE CONTROL.....	31
10.5 POTENTIAL POLLUTANTS AT A CONSTRUCTION SITE	32

10.6 EQUIPMENT MAINTENANCE.....	33
10.7 SPILL AND LEAK CONTROL	33
11 DESIGN, INSTALLATION, AND MAINTENANCE OF CONTROL MEASURES.....	34
11.1 USE OF CONTROL MEASURES	34
11.2 CHECK DAM (CD) / REINFORCED CHECK DAM (RCD).....	34
11.3 CONCRETE WASHOUT AREA (CWA)/GROUT WASHOUT AREA (GWA)	35
11.4 CONSTRUCTION FENCE (CF)/CONSTRUCTION MARKERS (CM)	36
11.5 DEWATERING AS IT RELATES TO SURFACE WATER (DW)	36
DESIGN	37
11.6 DIVERSION DITCH (DD)	37
11.7 EROSION CONTROL BLANKET (ECB).....	38
11.8 GRADE DIFFERENTIAL/CURB CUT BACK (GD/CCB).....	40
11.9 GROUT MIXING STATIONS (GMS)	41
11.10 INLET PROTECTION (IP).....	42
11.11 REINFORCED ROCK BERM (RRB)	43
11.12 SEDIMENT BASIN (SB)	43
11.13 SEDIMENT CONTROL LOG (SCL).....	45
11.14 SEDIMENT TRAP (ST).....	45
11.15 SEEDING AND MULCHING (SM)	46
11.16 SILT FENCE (SF).....	47
11.17 SLOPE INTERCEPT DITCH (SID)	48
11.18 STABILIZED STAGING AREA (SSA).....	48
11.19 STREET SWEEPING (SS).....	50
11.20 SURFACE ROUGHENING (SR).....	50
11.21 TEMPORARY SLOPE DRAIN (TSD).....	51
11.22 TEMPORARY STREAM CROSSING (TSC).....	51
11.23 VEHICLE TRACKING CONTROL (VTC)	52
11.24 VEHICLE TRACKING CONTROL WITH WHEEL WASH (WW).....	53
12 AUTHORIZATION OF THE GESC MANUAL	54

1 THE GESC PERMIT PROGRAM

This Grading, Erosion and Sediment Control Manual (*GESC Manual*) describes the permitting program adopted by the Southeast Metro Stormwater Authority (SEMSWA) to promote environmentally sound construction practices in the SEMSWA Service Area during land disturbing activities. The GESC Manual is authorized and approved by the SEMSWA Board of Directors, originally adopted on December 12, 2010 and subsequently amended from time to time.

The GESC Permit Program shall apply to the SEMSWA Standard Municipal Separate Storm Sewer System (MS4) Permit Area within the City of Centennial (City), hereinafter referred to as “permit area”.

The goal of the GESC Permit Program is to implement effective erosion and sediment control measures (formerly known as best management practices) as a standard for all land disturbing activities to reduce increases in erosion and sedimentation over pre-development conditions. During the relatively short period of time when undeveloped land is converted to urban uses or developed land is redeveloped, a significant amount of sediment can erode from a construction site and be transported to adjacent properties and receiving waters. Erosion caused by land disturbing activities, and the resulting downstream sedimentation, can damage property and degrade the quality of streams and lakes. Sediment is a transport mechanism for many stormwater pollutants. Eroded sediment can impact riparian and aquatic habitat and, since eroded sediments often contain significant phosphorus, this can lead to unwanted algae growth in lakes and reservoirs. SEMSWA is committed to protecting water resources and ensuring that future development continues in an environmentally sound manner.

The Cherry Creek Reservoir Control Regulation No. 72 (CR 72) identifies specific requirements for erosion and sediment control measures on construction sites within the Cherry Creek Reservoir Watershed draining into the Cherry Creek Reservoir, including placing limits on the area of land that can be disturbed at any one time. The intent of the regulation is to protect the water quality of the Cherry Creek Reservoir. SEMSWA’s permit area includes the Cherry Creek Reservoir Watershed area.

1.1 INTERPRETATION AND APPLICATION

In the interpretation and application of the provisions of this *GESC Manual*, the following shall govern: These provisions shall be regarded as the minimum requirements for the protection of the health, safety, comfort, convenience, prosperity, and welfare of the public. The GESC Manual shall, therefore, be regarded as remedial and shall be liberally construed to further its underlying purposes.

Whenever a provision in these criteria or any provision in any law, ordinance, resolution, rule or regulation of any kind, contain restrictions covering the same subject matter, **whichever is more restrictive or imposes higher standards shall govern**. If there is a discrepancy in the interpretation of the *GESC Manual*, the SEMSWA Technical Review Committee (TRC) shall make the final determination of the intent of the *GESC Manual*. Appeals to the TRC shall follow the process outlines in Section 4.12 of this Manual.

If a special district or other government entity with jurisdiction at the site imposes more stringent criteria, such differences are not considered conflicts. When differences arise, the more stringent requirements shall apply. If Federal or State law imposes stricter criteria, standards or requirements on SEMSWA through MS4, or other state

or federal permits, such shall be incorporated into these requirements after proper notice and public hearing(s) needed to modify the *GESC Manual*.

A GESC Permit is required prior to the start of any land-disturbing activities associated with construction within the SEMSWA's permit area in the City of Centennial in accordance with the GESC Permitting Matrix found on the SEMSWA web site at www.semswa.org.

Additionally, any project that the SEMSWA Executive Director determines to have an adverse impact on the public right-of-way, public infrastructure, or adjacent property, with respect to grading, erosion, and sediment control will be required to obtain a GESC Permit.

The *GESC Manual* shall not abrogate or annul any permits or approved drainage reports or construction plans issued before the effective date of this *GESC Manual*.

1.4 STATE AND FEDERAL PERMITTING

The State of Colorado and some Federal agencies require separate, additional permits for some construction-related activities. Applicants are responsible for contacting the Colorado Department of Public Health and Environment, Water Quality Control Division (WQCD); Federal Emergency Management Agency; and/or the US Army Corps of Engineers for specific permitting information for a project.

Information on some of the permits that may be applicable are included in the sections below. This is not to be considered a complete list.

STATE PERMITTING

In compliance with the Colorado Discharge permit System (CDPS) Stormwater Permit Program, the State requires that construction projects equal to or greater than 1 acre of disturbance, or less than 1 acre of disturbance if part of a Larger Common Plan of Development or Sale that is 1 acre or more, must obtain a Construction Stormwater General Permit and develop a Stormwater Management Plan (SWMP). It should be noted that a GESC Plan is not a SWMP (see Section 2.7).

In addition, the WQCD has several dewatering general permits. The permits establish water quality standards and control measures for dewatering discharges from construction sites. Additional permitting from the State Engineer's Office may be required if it is determined that there is a consumptive water use or loss.

In addition, air quality permits from the State may also be required.

FEDERAL PERMITTING

Applicants are also responsible for complying with all applicable Federal permits and requirements. This may include, but is not limited to, the Federal Emergency Management Agency (FEMA) map revision process, the United States Army Corps of Engineers (Corps) Section 404 Permit, and the United States Fish and Wildlife Service, Endangered Species Act Section 10 and/or Section 7 Permits. Applicants are advised to confirm the Federal requirements that may apply.

Projects that impact the regulatory floodplain may need to obtain a Conditional Letter of Map Revision (CLOMR) and/or Letter of Map Revision (LOMR) from FEMA. In this case, proper documentation needs to be submitted to FEMA for review and approval.

Excavation activity associated with a dredge and/or fill project in "Waters of the United States" (including streams, open water lakes, ponds, wetlands, etc.) may require a Section 404 Permit and/or other permitting. The level of permitting is dependent on the nature and extent of the disturbances within the water body of interest. The Corps

should determine if a Nationwide Permit or an Individual Permit is required. Individual Permits will require more detailed information about the project and preparation of exhibits specific to the project site.

1.6 AMENDMENTS AND REVISIONS

These policies and criteria may be amended and revised as new technology is developed and experience is gained. The SEMSWA Board of Directors, following the recommendations of the Executive Director (herein referred to as “Director”), may consider such amendments and revisions. Minor revisions, such as correction of typos or errors, that do not change any policy adopted in this Manual, may be amended with prior notice to the Board of Directors.

1.7 ENFORCEMENT RESPONSIBILITY

The SEMSWA Board of Directors, acting through the authority of the Director and its designee(s), shall enforce the provisions of the GESC Manual.

1.8 SPECIAL CONSIDERATIONS FOR CO-REGULATING MS4 PERMITTEES

To facilitate project permitting and the inspection process, and to avoid the need for duplicate plan review, approval, and permit issuance, SEMSWA may relinquish control of grading, erosion, sediment, and waste control requirements to a neighboring MS4 permittee’s Program if there is an agreement in place with the neighboring entity and a portion of the project is within that other jurisdiction’s program. The neighboring entity may assume full jurisdictional control for construction site stormwater runoff control activities, including plan review and approval, permit issuance, inspections, oversight and enforcement for the entire project, including those areas in the Permit Area, only when a site-specific agreement between the neighboring entity and SEMSWA exists.

Neighboring MS4 permittees may relinquish control of the grading, erosion, sediment, and waste control requirements to SEMSWA if a portion of the project is within their respective authorized MS4 area. A specific agreement between the neighboring entity and SEMSWA will be required.

SEMSWA shall reserve the right to protect their MS4 systems if contaminated water flows off the project and into the local storm sewer system per SEMSWA’s Illicit Discharge Program, up to and including all remedies available.

2 GESC PERMIT PROCESS CONSIDERATIONS

The GESC Permit Program was developed to ensure adequate design, implementation, maintenance and enforcement of Control Measures for stormwater quality management to prevent or minimize stormwater pollution from construction activities.

Construction activity includes any activity that disturbs the ground or land at the surface (land disturbance), such as, but not limited to, clearing, grading, excavation, demolition, installation of new or improved haul roads and access roads, staging areas, stockpiling of fill materials, and borrow areas. Construction does not include routine maintenance to maintain the original line and grade, hydraulic capacity, or original purpose of the facility. Activities to conduct repairs that are not part of regular maintenance or for replacement are construction activities and are not routine maintenance. Repaving activities where underlying and/or surrounding soil is cleared, graded, or excavated as part of the repaving operation are considered construction activities unless they are an excluded site under Part I.E.4.c.i. of the SEMSWA MS4 Permit. Construction activity is from initial groundbreaking to final stabilization regardless of ownership of the construction activities. Several administrative considerations have been included in this section to clarify the Permit process.

2.1 WHEN A GESC PERMIT IS REQUIRED

A GESC Permit is required prior to the start of any land-disturbing activities within the permit area in accordance with the GESC Permitting Matrix found on SEMSWA's website at www.semswa.org. Determination of which GESC permit to obtain can be found in section 3 "Type of GESC Permits".

Additionally, any project that the SEMSWA Director determines to have an adverse impact on the public right-of-way, public infrastructure, or adjacent property, with respect to grading, erosion, and sediment control will be required to obtain a GESC Permit.

2.2 PROJECTS COVERED UNDER OTHER PERMITS AND/OR PLAN

GESC Permits are required for projects meeting the GESC Permitting Matrix criteria within the permit area, even if a Federal or State agency, or another jurisdiction, has approved the project and issued their permit(s) for the work. The GESC Plan and Report are specific to the SEMSWA GESC Permit Program, and may not meet the requirements of other Federal or State environmental permit programs.

2.3 GESC PERMIT RESPONSIBILITY

GESC Permits shall be signed by both the Project Owner and the Contractor. Prior to issuance of a GESC Permit, the Owner and the Contractor are referred to as "Applicants." After the Permit is issued, both are considered "Permittees" and must comply with the GESC Permitting requirements. The specific contractual relationship between the Owner and Contractor as the Permittees must allow for immediate correction of deficiencies.

A Permittee is defined as "any person(s) who is issued a GESC Permit." The Permittee shall be legally responsible for compliance with the GESC Permit Program. If the Applicant is not an individual, an authorized agent of the entity must sign the permit on behalf of the Permittee.

Permittees conducting land-disturbing activities are responsible for meeting all requirements of the GESC Permit Program that are described in detail within the *GESC Manual*. Failure to meet the requirements of the GESC Permit

may lead to enforcement action (See Section 6, Enforcement).

2.4 REVIEW AND ACCEPTANCE LIMITATIONS

The GESC Permit Program submittals will be reviewed for compliance with the criteria contained herein. The acceptance of submitted documents by SEMSWA does not relieve the Owner, Design Engineer, Contractor, or Permittee(s) of responsibility for ensuring that calculations, plans, specifications, and construction comply with the criteria contained herein. Additionally, acceptance by SEMSWA does not alleviate the Owner, Design Engineer, Contractor, or Permittee(s) from complying with all other applicable Federal, State, or local laws or regulations.

2.5 PLAN AND REPORT AMENDMENT PROTOCOLS

Minor GESC Plan and Report modifications may be allowed without re-review and approval. The Permittee must update the GESC Plan and Report as necessary to reflect site conditions. All minor modification shall be implemented immediately and recorded on the GESC Plan. It is expected that the Permittee will need to make minor GESC modifications throughout a project to address changes in site conditions. Minor GESC modifications generally include Control Measure substitutions for other measures that are equivalent in performance and/or are more suitable to specific site conditions.

Major modifications to a GESC Plan are those involving re-engineering or changes to site hydrology (e.g. increased area tributary to a Control Measure; site conditions beyond the limits of a Control Measure; eliminating a Control Measure; changes to grading, drainage, or design intent). These modifications must be submitted to SEMSWA for review and acceptance. Control Measures that may be classified as a major modification are indicated with a “box” surrounding the Control Measure acronym, as indicated on the Legend (Appendix G).

2.6 WATER CONTROL PLAN REVIEW

In the rare instance where a construction project includes stream or conveyance channel crossings or improvements with active water flow, the GESC Plan/Report process includes the preparation of a Water Control Plan to identify the phasing of work necessary to meet controls required in “Waters of the United States” to meet Federal, State, and/or local laws and regulations. The Water Control Plan specifics will be discussed with SEMSWA needed. The Water Control Plan review fees shall be paid in accordance with the current SEMSWA Fee Schedule located on the SEMSWA website at www.SEMSWA.org.

2.7 A GESC PLAN IS NOT A SWMP

A GESC permit is required as part of the MS4 permit requirements to maintain and operate a construction program and implemented through a GESC Plan/Report submitted as part of the land development and plan review process. For sites disturbing 1 acre or more, or less than 1 acre of disturbance if part of a Larger Common Plan of Development or Sale that disturbs 1 acre or more, the Applicant is responsible for complying with the Colorado Discharge Permit System - Stormwater Construction Permit (CDPS - SCP) issued by the State. The CDPS-SCP requires a SWMP that is typically prepared by the Contractor, and not submitted for review by SEMSWA or the State. The GESC Plan and SWMP requirements are not the same, as they are implemented for two different permits.

It is the responsibility of the Applicant to comply with any CDPS – SCP requirements that are applicable to their site, including the development of a SWMP. Although each of these sets the broad goal of protecting water quality, each has slightly different compliance requirements. The GESC Permit and the CDPS – SCP permit require site inspections of a land disturbance project’s stormwater management system and that all Control Measures used are installed with sound engineering, and good hydrologic and pollution control practices. However, the path to achieving

compliance with the specific requirements of each permit may differ. It is important to note that it is possible to pass a GESC inspection at a site and not pass a state audit. It is important to understand what is required from both permits, as compliance with both permits must be achieved at all applicable land disturbance sites. A more complete understanding of the two permit's requirements for Control Measures and inspections, however, may allow the preparation and use of one plan for both permits.

3 TYPES OF GESC PERMITS

The GESC Permit Program allows for the following types of permits to be used:

- Standard GESC Permit
- Low Impact GESC Permit
- Single-Family Individual Lot GESC Permit
- Annual GESC Permit
- Low Risk GESC Process

To determine the appropriate GESC Permit for a project, refer to the GESC Permitting Matrix found on the SEMSWA website, www.SEMSWA.org. A discussion of each permit type and required plans and reports follows.

3.1 STANDARD GESC PERMIT

A Standard GESC Permit is required for construction activities as defined in Section 1. Conventional development and redevelopment projects have varied site conditions that need to be addressed with a complete GESC Permit process, also known as a Standard GESC Permit. These are more standard development and redevelopment projects with greater than 1/4 acre of disturbance, or less than 1 or more acres of disturbance as a part of a Larger Common Plan of Development or Sale that disturbs 1 acre or more. Standard projects may have multiple ownerships, or after development by one owner, will contain multiple lots that can be sold to a new owner(s). In addition, if any of the following conditions are within the described threshold below, the Standard GESC permitting process will be required even if the disturbance is less than 1 acre:

- If site construction activities require a permanent post construction Control Measure.
- If the site construction activities are within 100 feet of a drainageway and causes a disturbance within the floodplain that requires a floodplain engineering analysis or modification, and results in an impact to the floodplain.
- If the construction site activity alters established drainage patterns and requires a drainage analysis.
- If the construction site activity requires an Engineering Process or a substantially large volume staging of material, significant concrete or grouting work, or considerable waste material storage or generation. For example, a Temporary Batch Plant may require a stand-alone Standard GESC Permit if a Reclamation Plan is required.
- If SEMSWA determines that the construction activity has the potential to adversely impact drainage patterns, resulting in sedimentation of the stormwater system, or is of a sufficient volume to contribute to a water quality violation.

Control Regulation 72 requires the Applicant to submit for approval an Erosion and Sediment Control Plan describing approved construction Control Measures for land disturbances. SEMSWA shall approve the use of a Standard GESC Permit to meet Control Regulation 72 requirements.

REPORT REQUIREMENTS

Information relating to GESC required at the site shall be included in a separate GESC Report. See the GESC Report Checklist in Appendix E for information required to be included in a Standard GESC Report. The Report is an excellent place to clarify anything that cannot be clearly shown on the Plan, any special maintenance required over and above what is identified on the GESC Plan - Standard Notes and Details, and any calculations used in

the design of Control Measures.

PLAN REQUIREMENTS

The following requirements shall be adhered to when preparing a Standard GESC Permit Plan and Report. The GESC Plan and Report requirements are explained in this Section, and typically consist of three plan sheets to show Control Measures for the initial, interim and final phases of construction. The GESC Plan shall be consistent with the Approved Drainage Plan for the site. The GESC Checklists located in Appendix E should be filled out and submitted as an attachment to the GESC Report, to ensure that each of the requirements is addressed.

All Standard GESC Permit Plans shall be prepared on 22" by 34" sheets at a scale of 1-inch to 20-feet up to 1-inch to 200-feet, as appropriate, to clearly show sufficient detail for review. The final GESC Plan submitted for stamped approval may be half size. An Approval Block area with dimensions of 4.5" by 5.5", shall be reserved for the SEMSWA approval stamp (Appendix G).

The Standard GESC Permit Plan and Report shall be signed and stamped by the Design Engineer. In order to safeguard life, health, and property and to promote the public welfare, it is a requirement that the calculations necessary for a viable GESC Plan shall be prepared by or under the responsible charge of, and signed and stamped by, a Professional Engineer registered in the State of Colorado. (See Statutory Requirements in §§ 12-25-101, et seq., C.R.S.) For the purposes of this manual, the Professional Engineer is referred to as the Design Engineer.

Control measures must be selected, designed, installed, implemented, and maintained in accordance with good engineering, hydrologic, and pollution control practices. Good Engineering, Hydrologic and Pollution Control Practices: Methods, procedures, and practices that are based on basic scientific fact(s), reflect best industry practices and standards, are appropriate for the conditions and pollutant sources, and provide appropriate solutions to meet the associated GESC permit requirements.

COVER SHEET

The GESC Permit Program requires that all GESC submittals are stand-alone documents independent of other site civil construction drawings. Therefore, a separate cover sheet is required for GESC Permit Program documents (Appendix E, Section I).

INITIAL GESC CONTROL MEASURES

This plan sheet shall provide grading, erosion, sediment, and waste controls for the initial clearing, grubbing and grading of a project (Appendix E, Section III). These initial Control Measures shall be installed at the outset of construction, prior to the Preconstruction Meeting and after plan approval. This will ensure that the Control Measures will be installed prior to any other land-disturbing activities. Initial controls are to be placed on existing grades, but shall be based, as appropriate, on proposed grading operations. This sheet can be combined with the Interim GESC Control Measures sheet if both stages of Control Measures can be illustrated sufficiently for the Contractor to understand the timing of installation. Consolidating sheets shall be approved by SEMSWA.

INTERIM GESC CONTROL MEASURES

This plan sheet shows Control Measures to control grading, erosion, sediment and waste during the grading, site construction, and site re-vegetation process (Appendix E, Section IV). These Control Measures shall be based on proposed grades and drainage features, are installed after initial site grading, and as soon as practicable. Some interim controls are installed after construction of site infrastructure (e.g. Inlet Protection Control Measure after inlet construction).

FINAL GESC CONTROL MEASURES

This plan sheet shows controls for completion of site construction through the final stabilization phase (Appendix E, Section V). Control Measures shown in the Final Stabilization GESC Plan shall be installed as one of the last steps in the construction process, such as the final seeding and mulching stabilization Control Measure. If the development site is of a sufficiently low level of complexity, all three stages of Control Measures may be illustrated on one sheet. Consolidating sheets shall be approved by SEMSWA.

STANDARD NOTES AND DETAILS

A copy of the GESC Plan - Standard Notes and Details has been included in Appendix F and shall be provided with each set of the GESC Plan. This is to make sure the Contractor has all the relevant details provided within the site GESC Permit Program documents.

REQUIREMENTS FOR STAGED AND PHASED GESC PLANS

Areas of land disturbance equal to 40 acres or greater must not be exposed for more than 30 consecutive days without temporary or permanent stabilization. There may be allowable authorized exemptions to the 40-acre limit for removal and storage of cut material where geotechnical limitations restrict the use of temporary or permanent stabilization of the stored material (e.g. swelling soils, rock). Authorized exemptions to the 40-acre limit may be allowed when the Owner can demonstrate that the 40-acre limit is physically and/or financially impracticable. For sites granted this exemption, a phasing and earthwork quantities plan shall be submitted to SEMSWA and, following adequate review, approved by SEMSWA prior to the commencement of land disturbance activities. Submittal requirements include: (I) Phasing Plan/Earthwork Quantity Plan showing cut and fill volumes and locations for each Phase and project totals. (II) Erosion Control Plan showing specific erosion and sediment controls for each phase.

FEES AND COLLATERAL

Permit fees shall be paid in accordance with the current applicable Fee Schedule, located on the SEMSWA website at www.semswa.org. Collateral shall be submitted, based on the Control Measures required for site control (Section 4.11).

3.2 LOW IMPACT GESC PERMIT

Some land-disturbing activities may have only a minor potential impact on adjacent properties and downstream receiving waters. Low Impact permitted sites are less than 1 acre of disturbance and not part of a Larger Common Plan of Development or Sale that disturbs 1 acre or more, do not impact the floodplain, and are short in duration with small footprints that can be controlled with typical construction Control Measures, materials management, and good housekeeping practices. Low Impact GESC Permit projects do not require engineered construction Control Measures, such as those Control Measures that require volume sizing; therefore, no PE signature or stamp is required. These projects are typically home improvement projects or small additions to commercial slab-on-grade construction activities that may or may not require a separate Land Use process, and do not alter established drainage patterns.

Projects that fall under a Low Impact GESC Permit designation use an abbreviated GESC Plan process and may or may not require a GESC Report, typically in the form of a simple narrative.

Low Impact sites have a low level of a complexity such that construction Control Measures can be presented adequately in a simple sketch plan developed with or without the assistance of a Design Engineer. SEMSWA can be contacted to assist in the preparation of the Low Impact GESC Plan. This provides an excellent opportunity to

discuss the project and make sure all requirements are met.

For sites less than 1 acre within the Cherry Creek Basin with land disturbance not part of a larger common plan of development or sale that disturbs 1 acre or more, Control Regulation 72 requires the Applicant to submit for approval an Erosion and Sediment Control Plan describing approved construction Control Measures. SEMSWA shall approve the use of a Low Impact Permit as an abbreviated GESC Permit process that meets Control Regulation 72 requirements for sites under 1 acre.

Low Impact GESC Permit implementation procedures are contained in a Guidance Document found on the SEMSWA website at www.SEMSWA.org and provides details about the plan preparation, review and approval, and the issuance, inspection, enforcement, and close-out components of the permit. Requirements are paraphrased below. The determination of whether a project qualifies for a low impact permit shall be within the sole discretion of SEMSWA.

REPORT REQUIREMENTS

No GESC Report is required for the Low Impact GESC Permit, but based on the nature of the disturbance, a narrative may be required. This will be determined during Low Impact Permit plan review.

PLAN REQUIREMENTS

Although a detailed GESC Plan need not be prepared for sites where a Low Impact GESC Permit is appropriate, the following abbreviated GESC Plan shall be prepared and submitted to SEMSWA to provide enough information to determine if a Low Impact GESC Permit is acceptable for the proposed work:

A sketch plan all on one page, showing:

- All surface water hydrologic features that may affect work area.
- Directional flow arrows indicating grades that will determine stormwater runoff flow paths.
- Erosion, sediment, and waste Control Measures appropriate to the construction activity.
- Attached details for the designated construction Control Measures.
- Address roadways, north arrow and location map if possible.

FEES AND COLLATERAL

Permit fees shall be paid in accordance with the current SEMSWA Fee Schedule and collateral shall be submitted if determined necessary, based on the Control Measure(s) required for site control.

3.3 SINGLE-FAMILY INDIVIDUAL LOT GESC PERMIT

The Single-Family Individual Lot GESC Permit applies only to individual lot residential development. Single-family residential projects are required to obtain a GESC Permit even if they have a Building Permit. These sites have a low level of complexity, with established drainage patterns, such that the GESC Manual's Example Individual Lot Plans (Appendix D) can be used. This permit does not require engineered drawings and does not need to be signed and stamped by a Design Engineer. Applicants requesting a permit for *multiple* single-family lots, or choosing to combine several lots into a group, must obtain a Standard GESC Permit (Section 3.1).

In the Cherry Creek Basin, Control Regulation 72 requires the Applicant to control sediment before it leaves the

site using a single or multiple entrapment (perimeter) Control Measure(s). SEMSWA shall approve the use of the Single-Family Individual Lot GESC Permit Example Lot Plans in Appendix D for erosion and sediment control purposes for single-lot land disturbance in the Cherry Creek Basin to meet Control Regulation 72.

Note: Projects involving public improvements for a residential development project must follow the requirements of the Standard GESC Permit. Typical residential development requires a Standard GESC Plan and Permit and will not be issued a Single-Family Residential Individual Lot Permit.

REPORT REQUIREMENTS

No GESC Report is required for the Single-Family Individual Lot GESC Permit; however, based on the nature of the disturbance, a narrative may be required. This will be determined during the Single-Family Individual Lot GESC Plan Review process and may require discussion with the Applicant.

PLAN REQUIREMENTS

Appendix D provides example details with Single-Family lot erosion control plan details with typical drainage patterns. If the Applicant's lot conforms to the general layout and drainage patterns of one of these detailed lot plans, a lot specific GESC plan shall not be required. If the single-family residential lot does not conform to one of the example types provided, a specific lot GESC Plan shall be developed and submitted for review and approval.

The Single-Family Individual Example Lot Plans, provided in Appendix D, are the minimum requirements to control sediment transport from individual lots during single-family lot construction. The Example Lot details provided in Appendix D are provided to avoid the need for a plan review and approval process on each individual lot within a residential development. Use of the Example details of Control Measures for the permitted activity, however, is required. If alternate methods are going to be used on an individual residential lot, a specific lot GESC Plan depicting the Control Measures for that site may be submitted and reviewed on a case-by-case basis.

FEES AND COLLATERAL

Permit fees shall be paid in accordance with the current SEMSWA Fee Schedule and collateral shall be submitted if determined necessary, based on the Control Measure(s) required for site control.

3.4 ANNUAL GESC PERMIT

Land disturbance activities for similar, repetitive, and/or periodic maintenance operations, and dry utility installation projects under 1 acre and not part of a larger common plan of development or sale that disturbs 1 acre or more, are designated as Annual and are generally short term, frequent in occurrence, use the same or substantially similar design and construction processes, have the same type of waste discharge to manage, and require the same operational construction Control Measures.

These projects typically are done by public or quasi-public agencies or entities that perform the work with in-house staff or use experienced "short listed" or "on-call" contractors experienced with the requirements of maintenance and installation of public facilities. Projects that fall under an Annual Permit designation use an abbreviated GESC Plan process using SEMSWA-provided Fact Sheets and typical details of Control Measures installed for the anticipated activities. Annual Permits are issued in January; at year-end, any carry-over projects will require a new Annual Permit.

For sites within the Cherry Creek Basin with a land disturbance under an acre and not part of a larger common plan of development or sale that disturbs 1 acre or more, Control Regulation 72 requires the Applicant to submit for approval of an Erosion and Sediment Control Plan. The Plan should describe approved construction control measures. These documents shall be approved by SEMSWA.

The Annual Permit is on a calendar year basis and implementation procedures are contained in an Annual Permit Guidance Document on the SEMSWA website (www.SEMSWA.org) that provide details about the Fact Sheet, Permit Special Considerations, and typical details, permit issuance, inspection and enforcement, and close-out components of the Annual Permit. Requirements are paraphrased below.

REPORT REQUIREMENTS

No GESC Report is required for an Annual Permit; however, based on the nature of the disturbance, a narrative may be required. This will be determined during discussion with SEMSWA when the Applicant requests an Annual Permit for their construction and/or installation activities.

PLAN REQUIREMENTS

An Annual GESC Permit does not require a GESC Plan to be prepared or stamped by a Professional Engineer. However, the use of the GESC Permit Program's typical details of Control Measures for the permitted activity is required. A typical detail has been prepared to assist the Contractor or Applicant with the proper implementation of the appropriate Control Measure installation. If a standard detail does not exist for the proposed work, a specific plan may be required as determined by SEMSWA.

FEES AND COLLATERAL

Permit fees shall be paid in accordance with the current SEMSWA Fee Schedule. No collateral for an Annual Permit is required.

3.5 LOW RISK GESC PROTOCOLS

Some minor land disturbing activities, significantly less than 1 acre and not part of a larger common plan of development or sale that disturbs 1 acre or more, are not expected to contribute sediment to the stormwater system. These projects have a very low potential of causing a water quality impact and/or a violation of a water quality standard and are identified as "Low Risk." The GESC Permit Program does not allow a Low Risk designation for construction activities that have the potential to adversely impact drainage patterns or result in sedimentation of the stormwater system.

Low Risk construction activities are generally residential in nature, and typical of construction activities a homeowner or handyman service would undertake. Some smaller commercial construction incidental activities may also be considered Low Risk, such as re-skinning a building. The land disturbance is small, and significantly less than 1 acre; not part of a larger common plan of development or sale; located outside of the floodplain; and would not require any other SEMSWA permit. The activity is typically a one-time project, short in duration, condensed to one activity, and would not have the potential to affect established drainage patterns. No GESC Plan or Report is required.

The GESC Permit Program allows Low Risk sites to be managed without a formal permit if there is adherence to Control Measure(s) specified for the activity in available Fact Sheets prepared by SEMSWA. Failure to comply with the Control Measures established for the Low Risk designated activity could result in SEMSWA requiring a

GESC Permit to be obtained.

For these types of sites within the Cherry Creek Basin, the SEMSWA Fact Sheet will suffice as an erosion and sediment control plan, describing approved and appropriate construction Control Measures for the type of Low-Risk activity. SEMSWA shall approve the use of the Low Risk Fact Sheet documents as meeting Control Regulation 72 requirements for these condensed sites or projects under 1 acre with only minor land disturbing activities.

4 GESC PERMIT POLICIES

4.1 APPROVED GESC PLAN AND REPORT

The GESC Permit documents will be considered accepted and approved for construction when a completed application and submitted copies of the GESC Plan/Report is approved and stamped in the Approval Block. Applicants will be notified when the GESC documents have been signed and are ready to be picked up.

SEMSWA will retain two sets of the approved, signed GESC Plan/Report. The GESC Plan and Report documents are considered valid for 2 years following the signature date.

4.2 GESC PERMIT EXPIRATION

A GESC Permit is valid for 2 years from the date the permit is issued but may be administratively extended at SEMSWA's discretion. A GESC Permit must stay valid throughout the duration of a project, through final stabilization, and until close-out. Prior to permit expiration, the Permittee shall contact SEMSWA at least 30 days in advance to start the renewal process. Failure to renew the GESC Permit prior to its expiration may result in enforcement, as all sites need to be permitted until the site has met final stabilization requirements and closed out. Renewal fees for the GESC permit shall be in accordance with the current SEMSWA Fee Schedule. All applicable collateral is required to be in place for an active GESC Permit.

4.3 GESC PERMITS WITH PROPERTY OR PROJECT OWNERSHIP TRANSFERS

Multi-lot development typically involves the transfer of ownership of portions of the property or project during the life of the project, and they include common areas, which may serve or be impacted by multiple owners. It is important that Control Measures be in place to ensure that the GESC requirements are maintained on all portions of the original development throughout the life of the project. New Owners or the new Owner's Agent are responsible for obtaining a permit for any disturbed areas and should reference the GESC Permitting Matrix on SEMSWA website to determine Permit and Plans required. The SEMSWA Fee Schedule lists permitting fees associated with property or project transfers for a GESC Permit.

When a discrete portion of a development project is sold to a new Owner, the new Owner shall be required to obtain a GESC Permit for that portion of the property or project. A GESC Plan and Report for the property or project may exist and may provide the necessary Control Measure requirements. The new Owner may be required to provide new collateral in accordance with the GESC Permit requirements. This includes the situation when a GESC Permit is transferred from a Developer to a Homebuilder. The Developer must ensure the common areas are still permitted since they serve the entire site. These include the streets and rights-of-way, the common open space areas, drainage tracts and easements, stormwater detention and water quality facilities, and other areas that are not associated with the individual lots that are now in new ownership.

The original GESC Permit documents for the development may be adjusted throughout the life of the subdivision build-out to reflect only those improvements that are necessary. The cost estimate and collateral may be reduced accordingly, upon approval, throughout the project at the request of the Permittee.

The Permittee is responsible for all GESC requirements including subcontractors, utility providers and trades, unless they have their own Standard GESC permit. The Permittee may be required to revise GESC documents to reflect any new or revised permitted area(s) and must notify SEMSWA of the updated plan/ownership/construction limits.

If a different Contractor replaces the Contractor that is identified on the GESC Permit, the GESC Permit shall be transferred to the new Contractor. The transfer shall require a new GESC Permit, payment of a transfer/permit fee, and new collateral. Failure to transfer the GESC Permit to the new responsible Contractor or Permittee may result in enforcement.

4.4 RESPONSIBILITIES FOR SINGLE-FAMILY RESIDENTIAL PROJECTS

When individual lots are sold from a Permittee to a homeowner, the Permittee is responsible for notifying the new Owner of the single-family individual lot of the need to maintain the temporary erosion and sediment Control Measures on the site until the lot is final landscaped or re-vegetated in accordance with the GESC Permit Program requirements.

If the Permittee is not the one responsible for landscaping any portion of the lot, then once the property is transferred to a homeowner, the homeowner shall be responsible for the erosion and sediment control of the property. The Builder is responsible for ensuring temporary erosion Control Measures are designed to function for a minimum of 90 days after the transfer of ownership to the homeowner. The GESC Permit Program requires through its regulations that homeowners prevent the erosion and transport of sediment from their property. Homeowners are required to provide permanent stabilization of their lot, through such measures as sod, established seeded vegetation, rock, landscaping or other permanent measures of stabilization per applicable Land Development Code within 6 months of Certificate of Occupancy issuance. Homeowners are required to maintain temporary erosion Control Measures on their property, until permanent measures are installed and functioning.

4.5 GESC PERMITTEE SELLS A PORTION OF THE LAND/PROJECT AREA TO A BUILDER

When a Permittee sells a portion of their land/project area, the Permittee must remove that area from their GESC plan and notify SEMSWA of the updated plan, ownership, and construction limits. When individual lots are sold off to multiple owners, the lot owners will be required to obtain separate GESC permits for their lots and provide the required collateral to guarantee compliance with the GESC requirements. A separate GESC Plan may be required for these lots. Associated common areas and streets need to be accounted for in GESC permitting through an agreement that SEMSWA is aware of so that ownership and responsibility for GESC controls is clear and specific.

4.6 REVIEW FEE PAYMENT

Review fees are submitted with the initial GESC Permit submittal package. Review fees for a GESC Plan and Report are specified in the current SEMSWA Fee Schedule and are based on area of land disturbance.

4.7 CONSISTENCY WITH OTHER PLANS

The GESC Plan shall be consistent with approved plans such as drainage reports and construction drawings. The GESC Plan shall be submitted along with other related SEMSWA or City plans and permit applications. The Applicant may be required to obtain other permits as part of the project to facilitate development, including right-of-way access, construction of public improvement(s), and activities in the floodplain. These other related plans and permits may not reflect all requirements for development in the City. The Applicant should verify plans and permits required from the City specific to their development.

4.8 EARLY GRADING PERMIT REQUIREMENTS

To obtain the approval to perform early grading on a site where development approvals are imminent but before having approved Construction Documents, the project must have received a favorable recommendation from the Planning Commission, or if the project is not heard by a Planning Commission, approval by the Centennial City Council. In the event the plan is not required to go to either a Planning Commission or the City Council and will be administratively approved, the City's Planning Director must approve early grading. The GESC Report and Plan must be complete and approvable, the applicant must provide a Hold Harmless Letter and obtain applicable SEMSWA/ City permits, including appropriate ROW Permits as required, pay permit fees, and provide for collateral, to be allowed early grading approval (see Appendix B for an example Letter). At the appropriate time, the GESC Permit for the site will be issued. At no time will impervious area be created at the site as part of early grading.

4.9 PERMIT FEE PAYMENT

Permit Fees are to be paid prior to the GESC Permit issuance. Permit fees are identified in the current SEMSWA Fee Schedule, available through SEMSWA website, www.SEMSWA.org.

4.10 ENGINEERING COST ESTIMATES

Applicants are required to provide engineer's cost estimates (ECE) associated with implementing both the Initial/Interim GESC Control Measures and the Final Stabilization GESC Control Measures. An example of the two ECEs to be submitted is provided in Appendix C and provides unit cost information that shall be used to generate the cost estimate. The ECEs will quantify the collateral that will secure appropriate GESC Control Measures.

The collateral to secure GESC Control Measures will be held by SEMSWA until the Final Close-Out Acceptance. There may be a reduction in collateral between the Initial Close-Out and Final Close-Out upon request and approval.

SEMSWA may waive/reduce the ECE-based collateral amounts for governmental entities constructing public projects.

For projects that will be phased, the ECEs must be separated and sub-totaled for each phase of the project on the ECE calculation spreadsheets.

4.11 COLLATERAL POSTING

Collateral may be retained, based on the Control Measures required for site control during construction, and for site final stabilization. Collateral is required, as follows:

Permit	Collateral Required
Standard	Yes (Higher amount of Initial/Interim ECE and Final ECE)
Low Impact	Case-by-case basis*
Annual	No
Single Family	Case-by case basis*
Government Partner Agencies**	Yes, 10% of ECE or other agreed upon amount.

*Low Impact projects may require collateral depending on size, scope, and Control Measures required.

** Reduced collateral may be allowed from governmental entities based on an executed written agreement with SEMSWA addressing GESC requirements, Control Measure implementation and final stabilization.

The conditions under which the GESC collateral is held is separate from any other security relating to the project site’s Public Improvement Agreement (PIA) or any other agreements or permits relating to the site. GESC collateral will be retained and released separately per the *GESC Manual* requirements.

AMOUNT OF COLLATERAL

The amount of collateral for a GESC Permit is based on the higher of the ECE for installing and maintaining the GESC Control Measures required during construction (Initial/Interim), and for the site’s final stabilization (Final). A copy of the worksheets to be used for preparing the ECE for erosion and sediment Control Measures during construction, and for the site’s final stabilization, is included in Appendix C.

If the land disturbance site is over 20 acres, or the development has multiple or complex phasing plan, an alternate approach to collateral may be considered, as approved by SEMSWA.

FORMS OF COLLATERAL

SEMSWA accepts two forms of financial collateral:

- Irrevocable Letter of Credit from a Colorado financial institution in a form acceptable to SEMSWA. The Letter of Credit template is available on the [websites](#).
- Cash Escrow. An example of a cash escrow agreement is available upon request.

The conditions of each form of collateral shall allow the collateral to be held for a minimum of 3 years. The 3-year period should allow for completion of all GESC and other Agreement requirements, including two growing seasons to allow time for re-vegetation to reach the required coverage for Final Stabilization and GESC Permit close-out.

SEMSWA requires a Collateral Letter of Intent and a Letter of Credit. Templates for both documents can be found on the SEMSWA website at www.semswa.org.

EXPIRATION OF COLLATERAL

If the construction of the project and/or stabilization process takes longer than 3 years, the Permittee may extend the posted Letter of Credit for 1 year a minimum of 30 days prior to the expiration date. This extension must be requested by the Permittee. Failure to extend the collateral, prior to the 30 day deadline on an active site, may result in enforcement and/or SEMSWA drawing upon the collateral to ensure permit conditions are met. An

additional fee charged by the Permittee's financial institution may apply to extend the letter of credit.

The Permittee shall maintain the collateral amount required for the GESC Control Measures in full force and effect until Final Close-out approval of the GESC Permit, unless otherwise approved by SEMSWA.

RELEASE AND REDUCTION OF COLLATERAL

It is recognized that during the interim period between Initial Close-Out and Final Close-Out, conditions of the site may warrant alterations to the required final stabilization Control Measures. If the final stabilization Control Measures collateral amount is less than the Initial/Interim amount, the Permittee may request a reduction in collateral consistent with the reduced Control Measure amount as outlined in the Final ECE.

Once Final Close-out Acceptance for the site has been granted, the Final Close-Out form will be approved by SEMSWA and collateral for the project will be released. At any time, the Permittee may request a reduction in GESC collateral. The decision to reduce collateral is at SEMSWA discretion.

4.12 VARIANCES TO THE GESC MANUAL

No variance to the GESC Permit Program requirements as contained in the *GESC Manual* will be considered that would result in a noncompliance with SEMSWA's MS4 Permit. Outlined below is the process of submitting a variance request at a GESC permitted site and appealing a denied request for a variance from these standards. All GESC Permit Program variance requests will be submitted to SEMSWA initially for a technical analysis of the variance impact on sediment and erosion control at a site and determination of compliance with the MS4 Permit requirements. Below is the process for an appeal of a Variance Request determination.

VARIANCE CRITERIA

A variance shall be granted only upon the finding that the requested variance from the requirements of the GESC Permit Program will not impair the public health, safety, and welfare of the residents of the Permit Areas and that the intent and purposes of the GESC Permit Program to meet MS4 Permit requirements have been met. In ruling upon a variance, SEMSWA shall also consider the impacts the proposed alternative criteria would have on construction and maintenance requirements and cost.

VARIANCE AND APPEAL PROCEDURES

Step 1. Applicant submits a written request for a variance from the GESC Permit Program to SEMSWA with the variance request form found on the website at www.SEMSWA.org. At a minimum, the variance request must include the following information:

1. Identification of the criteria sought to be waived or varied;
2. Identification and detailed description of the alternative to the GESC Permit Program criteria; and
3. Justification of, and reason for, the variance request.

Step 2. SEMSWA is responsible for reviewing the variance request and deciding approval or denial based on adherence to the GESC Permit Program. The request shall be referred to the Technical Review Committee (TRC), consisting of engineering and technical management staff. TRC reviews the request and recommends either approval or denial. Upon the ultimate determination of approval or denial of a variance request, SEMSWA will

notify the Applicant of the determination.

Step 3. If the variance request is denied, the Applicant may appeal the decision by submitting a written appeal. Staff will forward the appeal request to the SEMSWA Director.

Step 4. Upon receiving the appeal request, SEMSWA shall respond to the Applicant by setting a date, time and location for a meeting to allow the Applicant to present their appeal. The meeting date shall occur within a reasonable time frame from the date the SEMSWA received the appeal.

Step 5. After the appeal meeting, SEMSWA shall render a written decision either approving or denying the variance request and provide to the Applicant within a reasonable time frame from the date of the appeal meeting.

Step 6. If the Director upholds the denial of the variance request, the Applicant may appeal the decision to the SEMSWA Board or Directors. To do so, the Applicant shall submit to the Director a written request to appeal and the Director shall notify the Applicant of the date, time and location of the public hearing at which the SEMSWA Board will consider the variance.

Step 7. The public hearing provides the Applicant and the SEMSWA staff an opportunity to present information relative to the variance request. The SEMSWA Board of Directors will evaluate the variance application and all presented information at the hearing and shall approve, conditionally approve or deny the variance. The SEMSWA Board of Directors shall base its decision on the information presented in consideration of the applicable GESC Permit Program requirements.

BURDEN OF PROOF

In all stages of appeal, the Applicant bears the burden of proof to establish that a variance from the GESC Permit Program is justified and does not result in a noncompliance with the MS4 Permit.

5 GESC PERMIT CLOSE-OUT

5.1 INITIAL CLOSE-OUT

Initial Close-Out may be requested when all disturbed areas are stabilized in accordance with the GESC Permit Program criteria. The GESC permit holder (Permittee) shall request an Initial Close-out Inspection from the SEMSWA Inspector (Inspector).

Prior to the Initial Close-Out Inspection, the following must be completed:

- Clean all streets, sidewalks and flowlines of sediment with a street sweeper. **WASHING OF STREETS, SIDEWALKS AND FLOWLINES IS IN DIRECT VIOLATION OF GESC MANUAL CRITERIA.**
- Clean all inlets, trickle channels and all other drainage features.
- Remove construction erosion and sediment controls (per the approved GESC Plan) and install/maintain final stabilization erosion and sediment Control Measures per the approved GESC Plan.

Once all items are completed, the Permittee shall call SEMSWA and schedule an Initial Close-Out Acceptance Inspection. In addition to the Inspector, a representative of the Permittee shall attend the Initial Close-Out Inspection.

The Permittee shall complete the Close-Out Form located on SEMSWA's website, www.SEMSWA.org.

Any corrections noted during the Initial Close-Out Acceptance Inspection shall be made to the site as requested by the Inspector, and when completed, a re-inspection can be scheduled with the Inspector.

Once the Close-Out Form has been provided to SEMSWA and the acceptance inspection is approved, the inspector shall grant Initial Close-Out.

5.2 REQUIRED INSPECTIONS AND MAINTENANCE AFTER INITIAL CLOSE-OUT

The Permittee shall undertake the following inspections and maintenance operations after Initial Close-Out:

- Seeded and mulched areas shall be inspected as necessary to ensure growth of vegetation by the Permittee for a period of two (2) growing seasons (Spring and Fall); following initial seeding, noxious weeds shall be controlled.
- Reseeding and mulching shall be undertaken as necessary after the two (2) growing seasons for any areas failing to meet the required coverage, or as requested by the Inspector.
- Final stabilization Control Measures shall remain in good working order at all times. Failure to do so may result in enforcement.
- The Inspector may approve alternative final stabilization criteria for specific operations or field conditions.

5.3 FINAL VEGETATION ACCEPTANCE

The Inspector will confirm on the Close-Out Form that vegetation has met the required coverage of 70% of the site's preconstruction condition, and that noxious weeds have been controlled. When the required coverage has been met, the Inspector will issue acceptance of the vegetation and give the Permittee instructions to remove remaining

final stabilization Control Measures.

If the required vegetation coverage is not met, repairs or corrections shall be made by the Permittee and a follow-up vegetation acceptance inspection can be scheduled once the vegetation meets the required coverage.

5.4 REMOVAL OF FINAL STABILIZATION CONTROL MEASURES

After obtaining written acceptance of the vegetation coverage from SEMSWA the remaining final stabilization Control Measures shall be removed and properly disposed. The site shall be cleaned up and any areas disturbed as a result of Control Measure removal shall be seeded and mulched, or otherwise final stabilized.

5.5 FINAL CLOSE-OUT INSPECTION

Prior to Final Close-Out Inspection the following must be done:

- Clean all streets, sidewalks and flowlines of sediment with a street sweeper. **WASHING OF STREETS, SIDEWALKS AND FLOWLINES IS IN DIRECT VIOLATION OF GESC Manual CRITERIA.**
- Clean all inlets, trickle channels and all other drainage features.
- Remove all controls at the site.
- Maintain all stormwater infrastructure to ensure proper functionality of the stormwater system.

The Final Close-out Inspection shall then be scheduled between the Inspector and the Permittee. The Inspector will check the removal of Control Measures, confirm that the final stabilization vegetation has been maintained as appropriate, and either accept the site as final, or stipulate the corrections that must be made. In the rare instance when corrections are substantial, the Inspector may require that follow-up inspections be scheduled until the site is final stabilized.

6 ENFORCEMENT

Failure to comply with any term, condition, limit, deadline or other provision of the GESC Permit Program, the GESC Permit, or failure to obtain a GESC Permit or keep an active GESC Permit or Plan/Report, shall constitute a violation of the GESC Permit Program. Discharge of any pollutant offsite, including sediment, is a violation and subject to enforcement.

Per SEMSWA's Enforcement Response Plan found on SEMSWA's website at www.SEMSWA.org, in addition to any other legal or equitable remedies that SEMSWA may have for GESC violations, may at its discretion, use any or all of, but not limited to, the following enforcement:

- verbal warnings with education;
- issue compliance assistance re-inspection fees and/or penalty fees;
- withhold issuance or extensions of permits;
- withhold inspections;
- issue Preliminary Notice of Violation warning letters or an NOV;
- issue Stop Work Order;
- revoke GESC permit;
- pull collateral;
- conduct abatement; or
- refuse to issue any other necessary approvals until such violation has been corrected and the Permittee has taken the necessary action to ensure compliance with the GESC Permit and GESC Permit Program requirements.

6.1 NONCOMPLIANCE

In the event the Permittee is not meeting the requirements of the GESC Permit Program, GESC Plan/Report, and/or GESC Plan - Standard Notes and Details, and is therefore in noncompliance, remedies will be available to SEMSWA in accordance with the remedies contained herein, other legal or equitable remedies, and/or any Resolution(s) or Policies containing provisions for providing remedies for enforcement against defaults or violations. The following list identifies actions that constitute noncompliance; however, noncompliance actions are not limited to the list below. SEMSWA's Enforcement Response Plan explains what constitutes noncompliance, the tools used to enforce on violations, and detail the escalation procedures for sites requiring enforcement.

- Failure to obtain a GESC Permit or starting work before a GESC Permit is issued.
- Permittee fails to install Control Measures, or fails to construct the improvements in substantial compliance with the GESC Plan and the other requirements of the GESC Permit or GESC Permit Program;
- Permittee fails to repair, replace, and/or maintain a Control Measure that has the potential to, or causes a discharge of pollutants offsite when a verbal request has been made to immediately correct the deficiency;
- Permittee fails to correct any noncompliance specified on an Inspection Form or in any written notice of noncompliance within the time frame specified;
- Permittee otherwise breaches or fails to comply with any obligation of the GESC Permit and/or GESC Permit Program not specifically identified herein;
- Permittee become insolvent, files a voluntary petition of bankruptcy, is adjudicated as bankrupt pursuant to an involuntary petition in bankruptcy, or a receiver is appointed for the Permittee;

- Permittee fails to maintain in full force and effect a Letter of Credit to secure collateral in the amounts specified in the GESC Permit. Notice of defaults as to any phase of GESC must be given prior to expiration of the warranty period for such phases of the SIA, PIA or other agreement, as hereinafter provided.
- Permittee fails to submit a cut sheet of any alternative erosion or sediment control measure installed onsite in the time frame specified.

Additional noncompliance actions may be determined at the discretion of SEMSWA based on an assessment of the action in relation to a violation of the *GESC Manual*, GESC Permit, and/or GESC Permit Program.

6.2 RIGHT TO COMPLETE GESC CONTROL MEASURES

SEMSWA shall have the right to complete the GESC Control Measures to correct any GESC Permit default, either itself or by contract with a third party or by assignment of its rights to a successor who has acquired the subdivision/project by purchase, foreclosure, or otherwise.

SEMSWA shall be entitled to: (a) make a draw on the Letter of Credit or cash collateral for the amount reasonably determined to be necessary to correct the default in a manner consistent with the approved GESC Plan up to the face amount of the Letter of Credit or cash collateral; and (b) sue the Permittee for recovery of any amount necessary to correct the default over and above the amount available under the Letter of Credit, or lien the property.

6.3 USE OF FUNDS

Any funds in the possession of or obtained by SEMSWA may be used to pay the costs of site control and/or stabilization and to pay the reasonable costs and expenses in connection with the GESC Permit default by Permittee(s), including reasonable attorneys' fees.

7 FIELD POLICIES

7.1 RESPONSIBILITIES OF THE GESC MANAGER

As the Permittee's focus shifts from preparing the GESC Plan and Report and applying for the GESC Permit, to constructing the project, the first task is to select a site GESC Manager. The GESC Manager is the Permittee contact person with the Inspector for all matters pertaining to the GESC Plan and Permit and shall respond to requests made by the Inspector and have any deficiencies in the work corrected. The GESC Manager may be an employee of the Owner or Contractor and shall have the authority to act on behalf of the Permittee, including committing funds, to ensure that the site remains in compliance with the GESC Permit. In all matters, the Permittee shall remain the legally responsible party.

An Alternate GESC Manager who can serve in the same capacity as the GESC Manager shall also be selected. The GESC Manager shall inform the Alternate GESC Manager of any absences, provide the Alternate the status of the GESC Plan implementation, and ensure that the Alternate GESC Manager assumes the GESC Manager's responsibilities during any absence. The GESC Manager and Alternate GESC Manager shall be named at the onsite Preconstruction Meeting.

7.2 AVAILABILITY OF THE GESC MANAGER

The GESC Manager shall be on site as necessary to ensure the GESC Plan/Report requirements are being implemented and shall provide the Inspector with contact information, including email and phone. The contact information will ensure that the GESC Manager can be contacted to provide adequate site status updates. In the event the GESC Manager (or Alternate GESC Manager) cannot be reached within 24 hours, and a GESC issue is urgent, a violation may be assessed.

7.3 CHANGING THE GESC MANAGER OR ALTERNATE

Notification shall be provided to the Inspector if the GESC Manager or Alternate change. A field meeting with the Inspector and new GESC Manager or Alternate should be scheduled prior to the next scheduled inspection to discuss site conditions and responsibilities of the GESC Manager.

7.4 DOCUMENTS THAT SHALL REMAIN ON SITE

A copy of the project's approved GESC Plan/Report, GESC Plan - Standard Notes and Details, and GESC Permit shall remain on site, unless otherwise approved by the Inspector, and shall be made available at the SEMSWA Inspector's request.

7.5 PRECONSTRUCTION MEETING

An onsite Preconstruction Meeting is required prior to GESC Permit issuance. This is the opportunity for the Inspector to verify that initial sediment, erosion, and waste Control Measures are in place and the site is ready for construction activity; the GESC Permit application can be approved; and the Permit issued. In addition to the Inspector and the GESC Manager, the following representatives should attend:

- General Contractor.
- Owner or Owner's Representative (the General Contractor may **NOT** be the owner's representative).

- Alternate GESC Manager (may be the same as the Owner or General Contractor Representative).
- Grading Sub-Contractor, if different than the General Contractor.

If the Inspector determines that significant modifications or corrections to the initial GESC Control Measures are necessary, the Inspector will inform the GESC Manager that such corrections shall be made, and that a follow-up inspection shall be scheduled with the Inspector. At no time can construction activities be initiated until appropriate Control Measures are in place. Acceptance of the corrected Control Measures by the Inspector shall take place prior to the issuance of the GESC Permit.

The Permittee shall not start site grading activities prior to the GESC Permit being issued. Issuance of the Hold Harmless letter in the case of early grading activities requires an approved GESC Plan/Report, GESC Permit, and GESC collateral.

7.6 TOPSOIL PRESERVATION

Topsoil stripping and stockpiling of disturbed area topsoil is a critical component in establishing the required vegetative coverage for final stabilization. Stripping, stockpiling, and re-spreading of the former in-situ topsoil in areas to be vegetated shall be a mandatory practice and specified in all GESC Plans.

7.7 STABILIZATION

All areas disturbed by construction, and soil stockpiles, shall be stabilized as soon as possible to reduce the duration of soil exposure to runoff events and the potential for erosion. All disturbed areas which are either final graded or will remain inactive for a period of more than thirty (30) days, shall be required to be stabilized within fourteen (14) days of the completion of the grading activities. Reworking the disturbed area within the thirty (30) days for the sole purpose of avoiding the requirement to stabilize the exposed area shall not be considered an acceptable practice. Acceptable stabilization Control Measures are as follows.

- Surface roughening **and** Mulching,
- Seeding and Mulching (acceptable if area will remain dormant for more than six (6) months; temporary seed mix is acceptable), or
- Erosion Control Blanket, or acceptable equivalent control.

For temporary stabilization (i.e. areas that will be reworked), the GESC Permit Program requires one of the above. All stabilization Control Measures must be maintained.

As soon as possible after construction in drainageways, or after removal of a temporary stream crossing, all disturbed areas shall be top-soiled, seeded and mulched, and, unless otherwise approved, protected with Erosion Control Blanket.

7.8 INSTALLATION OF INTERIM AND FINAL CONTROL MEASURES

It is the responsibility of the GESC Manager to ensure that Interim Control Measures and subsequent Final Control Measures are installed at the earliest opportunity. Some Control Measures have specific time requirements for installation that are identified on the GESC Plan - Standard Notes and Details; these time requirements shall be adhered to.

For Control Measures where a specific time frame is not given, the controls shall be installed as soon as construction

of the infrastructure is substantially complete or when grading activities have produced grades close to the final grade. In these cases, it is up to the discretion of the Inspector to make the final determination of Interim and Final Control Measure installation time frames.

8 REQUIRED GESC INSPECTIONS

8.1 GESC INSPECTIONS CONDUCTED BY GESC PERMIT HOLDER

During the construction phase, erosion, sediment, and waste controls must be inspected regularly by the site GESC Manager to ensure that the Control Measures are adequately installed, maintained and functioning as intended.

Sites with a State Stormwater Construction General Permit must have a self-documented inspection conducted of site Control Measures to ensure installation and maintenance is per the site's SWMP requirements.

Sites that are inactive with no construction activity on site must have a documented inspection of GESC controls conducted every 30 days by the site GESC Manager.

Sites with a State Stormwater Construction General Permit that are inactive with no construction activity on site must have a documented inspection of SWMP controls conducted every 30 days.

For areas within the Cherry Creek Basin, the GESC Manager must inspect BMPs at the following times and intervals at a minimum:

- After installation of any Construction control measure;
- After any runoff event; and
- At least every 14 days.

For sites where construction activities are completed but final stabilization has not been achieved due to a vegetative cover that has been planted but has not become established, the Permittee may reduce the inspection frequency to once every 30 days.

The GESC Manager shall provide Inspection Reports to the Inspector upon request.

8.2 GESC INSPECTIONS CONDUCTED BY SEMSWA

During the construction and final stabilization phase, erosion, sediment and waste controls will be inspected regularly by the Inspector. The Inspector will consider the overall effectiveness of the controls and will generally check for proper installation and maintenance of the controls. It remains the responsibility of the Permittee/GESC Manager to ensure that the site remains in compliance with all GESC requirements.

9 SITE GRADING DESIGN GUIDANCE AND CRITERIA

This section provides design guidance and criteria for developing a proposed grading plan for a site. Although the existing topography and planned uses of development sites and individual lots are unique, several principles apply when designing permanent land surface grading.

9.1 SLOPES

The topography of a site may be existing steep slopes that are to be preserved, or cut or fill slopes created during the grading process. In either case, the measures in this section shall be taken to protect slopes from erosion.

On steep or sloping sites, or flat sites where more variation in grade is desired, the proposed grading plan may incorporate graded slopes and/or retaining walls.

Preferred slopes are 4:1 or flatter, designed with variation and shaping as appropriate, possibly utilizing a Landscape Architect.

Slopes between 3:1 and 4:1 are problematic; these slopes require stabilization with Erosion Control Blanket.

Slopes steeper than 3:1 are highly discouraged, will require additional permanent measures to withstand erosion, and may require a variance (Section 4.12).

9.2 STOCKPILES

During design, earthwork balance and timing of construction will determine the necessity of stockpiling. If stockpiling is anticipated, it must be noted on the GESC Plan, and must be within approved construction limits.

Stockpiling of material on construction sites or undeveloped lots shall be allowed only as a temporary condition for a maximum of six (6) months, unless otherwise approved by SEMSWA. Stockpile types and locations may be reviewed and approved by the Inspector. The following criteria apply to all stockpiles:

- Side slopes of stockpiles not being actively worked must be flatter than 3:1. Appropriate Control Measures to control erosion of the slopes must be used.
- Soils that will be stockpiled for an extended period must be stabilized. If soil is to be stockpiled for more than 30-days and not actively worked, it shall be seeded and mulched within 14-days of stockpiling. If material is removed from the stockpile periodically throughout the life of the stockpile, appropriate Control Measures must be provided to address the disturbance caused by the removal operations.

10 GENERAL CONSTRUCTION PRACTICES

The Permittee and Contractor have the responsibility to review, understand, and comply with the GESC Plan - Standard Notes and Details. Several GESC Permit Program requirements pertaining to general construction practices are highlighted in the following sections. Noncompliance with these construction practices is not acceptable, will be a violation of the GESC Permit, and can be enforced upon by the Inspector.

10.1 LIMITS OF CONSTRUCTION

No work, storage of equipment, or stockpiling shall be allowed outside of the approved Limits of Construction. The Limits of Construction must be complied with and are enforceable by the Inspector.

10.2 STREET CLEANING

Throughout the life of a project, streets used for egress shall be kept clean and free of sediment that can be tracked. In the event of accidental tracking of mud or dirt on streets, the mud and/or dirt shall be cleaned immediately using a vacuum-type street sweeper, a brush-type street sweeper with dust control, or manually using shovels and brooms.

Any damage to the street from mechanical methods of street cleaning shall be repaired at the Permittee expense.

Streets can only be cleaned with water if all wash water is captured and prevented from entering the storm sewer system.

Tracking of sediment from a construction site is not acceptable, is a violation of the GESC Permit, and can be enforced by the Inspector.

10.3 DUST CONTROL

The GESC Manager shall be responsible for dust control on the site. Disturbed areas not yet ready to be seeded, land-scaped, paved, or otherwise stabilized, shall be watered, sprayed with a tackifier, mulched (without seed) or ripped as necessary to preclude visible dust emissions.

Dust that leaves the site in any amount that can be considered a safety issue is not acceptable, is a violation of the GESC Permit, and can be enforced upon.

10.4 CONSTRUCTION SITE WASTE CONTROL

Many potential pollutants other than sediment are associated with construction site activities. These pollutants include, but are not limited to, pesticides; fertilizers used for vegetative stabilization; petrochemicals; construction chemicals such as concrete products, sealers, and paints; wash water associated with these products; trash; paper; wood; garbage; detergents and solvents; and sanitary wastes. These wastes are described in Section 10.5.

Responsible handling and adequate disposal facilities shall be utilized for solid waste, including excess asphalt, concrete, wood, rebar and other construction wastes produced during construction.

Washing of equipment and machinery shall not be allowed on site, is a violation of the GESC Permit, and can be enforced upon.

Appropriately store, cover, and/or isolate all onsite potential construction-associated waste pollutants to prevent runoff of pollutants and contamination of ground water. The GESC Manager is responsible for both the management and cleanup of potential construction waste. Outdoor storage of bulk liquids is required to have secondary containment or equivalent protective measures in place.

Outdoor storage or any of the above items shall not be stored within the floodplain, is a violation of the GESC Permit, and can be enforced upon.

10.5 POTENTIAL POLLUTANTS AT A CONSTRUCTION SITE

Pollutant sources onsite must be identified and controlled using structural and/or non-structural controls to the Maximum Extent Practicable (MEP) as determined by the Inspector. Detailed descriptions of structural Control Measures for pollution control are given in Section 11. Though not an exhaustive list, the following are examples of common pollutant sources found on construction sites.

Failure to control any of these pollutant sources, or other potential pollutants is unacceptable, is a violation of the GESC Permit, and can be enforced by the Inspector.

PESTICIDES

Insecticides, fungicides, rodenticides, and herbicides are used on construction sites to reduce maintenance and fire hazards associated with weeds and woody plants. Rodenticides are also used to control rodents attracted to construction sites. Common insecticides employed include synthetic, relatively water-insoluble chlorinated hydrocarbons, organophosphates, carbamates, and pyrethrins.

PETROLEUM PRODUCTS

Petroleum products used during construction activities include fuels and lubricants for vehicles, for power tools, and for general equipment maintenance. Specific petroleum pollutants include gasoline, diesel oil, kerosene, lubricating oils, and grease. Asphalt paving also can be particularly harmful since it releases various oils for a considerable time after application. Additionally, many of these pollutants adhere to soil particles that can leave the site in runoff and pollute receiving waters.

NUTRIENTS

Fertilizers are used on construction sites when re-vegetating graded disturbed areas. Fertilizers contain nitrogen and phosphorus, which in large doses can adversely affect surface waters, causing eutrophication.

SOLID WASTES

Solid wastes on construction sites are generated from trees and shrubs removed during land clearing and structure installation. Other wastes include wood and paper from packaging and building materials, scrap metals, sanitary wastes, rubber, plastic and glass, and masonry and asphalt products. Common trash, including food containers, cigarette packages, leftover food, and aluminum foil also contribute to solid wastes at the construction site.

CONSTRUCTION CHEMICALS

Chemical pollutants, such as paints, acids for cleaning masonry surfaces, cleaning solvents, asphalt products, soil additives used for stabilization, sanitary wastes, and concrete curing compounds, may also be used on construction sites and carried in runoff.

SEDIMENT

Sediments are soils or other surficial materials transported or deposited by the action of wind, water, ice, or gravity, and often as a product of erosion. Sediments from construction sites can erode from land disturbed by the construction activities during a rainfall event that can leave the site in runoff.

10.6 EQUIPMENT MAINTENANCE

Equipment maintenance is to be conducted in the designated location within the Limits of Construction. Maintenance should not be conducted within 50 feet of a conveyance swale, drainageway, and/or storm sewer inlets.

10.7 SPILL AND LEAK CONTROL

Spills and leaks onsite must be cleaned up using dry methods whenever possible. If water or other liquid methods are used, the wash water must be collected and disposed of properly. Spilled substances and any associated cleaning residue must be prevented from reaching receiving waters and/or entering the storm sewer system.

Effective spill control is required to be implemented on construction sites. Onsite personnel must be trained on both spill prevention and spill response measures.

11 DESIGN, INSTALLATION, AND MAINTENANCE OF CONTROL MEASURES

This section identifies several temporary Control Measures accepted for use to control erosion and sediment runoff from construction sites. This section of the *GESC Manual* provides the design parameters to be specified for each Control Measure on the GESC Plan and the accompanying GESC Plan – Standard Notes and Details, criteria for sizing Control Measures, and required maintenance for each Control Measure.

11.1 USE OF CONTROL MEASURES

The GESC Plan submitted to SEMSWA for approval and subsequently provided to the Contractor with the final construction drawings shall include a set of the GESC Plan - Standard Notes and Details. If there is a conflict between the design, installation, and/or maintenance of a Control Measure in the GESC Manual and the GESC Plan - Standard Notes and Details, the Inspector will determine the appropriate reference to use.

The GESC Permit Program recognizes that there will be new advances in the development of erosion and sediment Control Measures that may prove effective, or even out-perform controls currently accepted. SEMSWA may allow the installation of alternative erosion and sediment Control Measures other than the GESC Plan - Standard Notes and Details. If alternative erosion and sediment Control Measures will be used, a cut sheet must be submitted to the Inspector.

SEMSWA reserves the right to reject any Control Measure proposed or conditionally implemented. If the Control Measure does not perform with sufficient effectiveness, it would be considered a failed control by the Inspector. In the case of a failed alternate Control Measure, one or more of the GESC Permit Program's standard Control Measures shall replace the failed control, at the Permittee's expense.

Standard GESC Control Measures are listed here in alphabetical order for easy reference.

11.2 CHECK DAM (CD) / REINFORCED CHECK DAM (RCD)

The purpose of the Check Dam (CD) is to trap sediment in the backwater zone upstream of the check and, when used in series, to reduce flow velocities. CDs are used only for construction activities within a drainageway. CDs are not to be used to capture sediment transport from any activity near the stream. Once sediment is in the stream from a construction activity, it is a violation of the GESC Permit, and can be enforced upon. Therefore, appropriate Control Measures shall be used upland to keep sediment from entering the drainageway. The State does not recognize the use of any Control Measure within drainageways. Any Control Measure placed within a drainageway must have the appropriate permit from the Corps.

A Reinforced Check Dam (RCD) is a rock dam contained within a twisted wire gabion, designed to withstand overtopping, that is placed in a major drainageway. Like a check, the purpose of the reinforced check is to trap sediment in the backwater zone upstream of the check. The reinforcement increases the ability of the rock dam to withstand the larger overtopping flows of major drainageways.

If disturbance to a drainageway is significant, such that excessive amounts of sediment may be transported downstream, a CD, reinforced or non-reinforced, shall be installed immediately downstream of the disturbed area in the drainageway. If several areas of disturbance are in close proximity, one CD at the downstream end of the construction may be appropriate. In general, CDs will be used infrequently at typical construction sites since Control Measures shall be configured to control erosion and trap sediment outside of the limits of drainageways; CDs are

only to be used for specialized, permitted stream channel work.

DESIGN

Design parameters to be specified on the GESC plan include the following items:

- Type of check dam (check dam or reinforced check dam).
- Length (L) dimension.
- Crest length (CL) dimension.
- Depth (D) dimension.

The type of check is based on the drainage area upstream of the CD. An RCD shall be used for drainage areas greater than 130 acres. A non-reinforced CD may be used for drainage areas less than 130 acres or as approved by SEMSWA. A Reinforced Rock Berm (RRB) may be used as a check dam for drainage areas less than 20 acres (see Section 11.11).

Dimensions are to be specified to ensure that the check conforms to the existing drainageway cross section shape and provides adequate overtopping capacity.

INSTALLATION AND MAINTENANCE

Key Installation and Maintenance Requirements of CD and RCD:

- Riprap utilized for CDs shall be sized to withstand overtopping and to fit the drainageway and shall be sized per UDFCD criteria.
- Minimum size riprap shall be VL.
- Riprap pad shall be trenched into the channel banks to adequately anchor with the center of the check dam lower to allow for overtopping at the crest.
- Sediment accumulated upstream of the CD shall be removed when the sediment depth upstream of the check dam is within approximately 1/2 of the height of the crest.
- Gabions shall have galvanized twisted wire netting with a maximum opening dimension of 4 1/2" and an appropriate gauge to withstand anticipated flows. Wire hog rings at 4" spacing or other approved means shall be used at all gabion seams and to secure each gabion to the adjacent gabion.
- The GESC Manager shall inspect the CD and/or RCD and maintain in good operating condition.

11.3 CONCRETE WASHOUT AREA (CWA)/GROUT WASHOUT AREA (GWA)

A concrete and/or grout washout area is a contained area to isolate concrete truck and grout washout operations. A Concrete Washout Area (CWA) shall be provided when concrete work is performed. A Grout Washout Area (GWA) shall be provided when grout work is performed.

DESIGN

- If there is a potential for high ground water, the CWA/GWA must have an impervious liner. For portable concrete washouts, sizing of the portable container should be per the manufacturer recommendations.
- The CWA/GWA shall be located a minimum of 50 feet from storm drain inlets, open conveyance channels, drainage facilities and waterways.

INSTALLATION AND MAINTENANCE

Key Installation and Maintenance Requirements for CWA:

- A sign shall be placed at each washout area to clearly indicate the location of the CWA/GWA to operators of concrete trucks and pump rigs.
- Excavated material may be utilized in perimeter berm construction.
- If there is a potential for high ground water, the CWA/GWA must have an impervious liner.
- The CWA/GWA shall be repaired, enlarged, and/ or cleaned out as necessary to maintain capacity for wasted concrete.
- As needed during construction and at the end of construction, all concrete or grout waste shall be removed from the site and disposed of at an approved waste site.
- The GESC Manager shall inspect washout areas and maintain in good operating condition.

11.4 CONSTRUCTION FENCE (CF)/CONSTRUCTION MARKERS (CM)

Construction Fence (CF) consists of orange plastic fencing or other SEMSWA accepted material attached to support posts and is used to delineate Limits of Construction and to control access to the construction site. When construction within a drainageway is unavoidable, the Design Engineer shall delineate construction limits that restrict activities to the smallest area possible. CF or Construction Markers (CM) shall be indicated on the GESC Plan within the drainageway corridor to indicate the allowable limits of disturbance. In the same manner, CF or CM shall be shown on the GESC Plan throughout the site to identify all Limits of Construction, except in the case of single-family individual lot home construction (Section 3.3).

DESIGN

Design parameters to be specified on the GESC Plan include the following items:

- Location of construction fence or line of markers.
- Length (L) in lineal feet of construction fence or line of markers.

CF or CM shall be shown throughout the site to identify the Limits of Construction. CF or an appropriate alternative method of delineating the project limit shall be required along all drainageways and sensitive resources.

INSTALLATION AND MAINTENANCE

Key Installation and Maintenance Requirements for CF/CM:

- CM consisting of painted or flagged lath at approximately 100-foot spacing may be used to delineate the Limits of Construction, if approved by SEMSWA.
- Steel tee posts shall be utilized for support of construction fence as appropriate to site conditions.
- The GESC Manager shall inspect CF/CM and maintain in good operating condition.

11.5 DEWATERING AS IT RELATES TO SURFACE WATER (DW)

Dewatering controls typically consist of a gravel filter provided on the suction end of a pump to reduce the pumping of sediment, and a riprap pad at the discharge end of the pump for erosion protection. DW may require a sediment basin or filter bag large enough to provide for settling before the water is discharged onto the ground for infiltration or to a temporary settling basin.

Dewatering of groundwater operations is covered by State permits. The Permittee is responsible for obtaining and complying with State-issued permits.

DESIGN

Design parameters to be specified on the GESC Plan include the following items:

- The location of all proposed DW operations.
- The recommended size of the dewatering pump. The size shall be determined to provide sufficient capacity for the proposed pumping rates and may be modified by the Contractor if necessary.
- In addition, SEMSWA may require a Water Control Plan if site conditions warrant.

INSTALLATION AND MAINTENANCE

Key Installation and Maintenance Requirements for DW:

- All DW shall be in accordance with the requirements of any State permits.
- DW operations shall use one or more of the dewatering sumps shown in the GESC Plan - Standard Notes and Details or other means approved by SEMSWA to reduce the pumping of sediment and shall provide a temporary basin for settling pumped discharges prior to release.
- The discharge point shall be to a stabilized area.
- The discharge end of the line shall be staked to prevent movement from the stabilized discharge point.
- Maintenance shall occur per manufacturer's specification for dewatering bags, and replaced when full or ruptured.
- Sediment shall be removed from sediment basins when volume is reduced by 50%.
- The GESC Manager shall inspect dewatering systems and perform any necessary repairs or maintenance as necessary.

11.6 DIVERSION DITCH (DD)

A Diversion Ditch (DD) is a small earthen channel used to divert and convey runoff, generally to a Sediment Basin, Check Dam, or Reinforced Rock Berm. Depending on slope, the DD may need to be lined with one of the following: Erosion Control Blanket, plastic (for temporary installations only), PVC, or riprap.

A temporary DD may be necessary at upslope and downslope perimeters, at the top of steep slopes, and downstream of slope drains. DD shall be sized and stabilized according to the criteria below.

DESIGN

Design parameters to be specified on the GESC Plan include the following items:

- Lining of DD (earth, Erosion Control Blanket, riprap, or plastic).
- Length of each type of ditch.
- Depth (D) and width (W) dimensions and slope.
- Location.
- In addition, if the ditch lining is Erosion Control Blanket or riprap, the type of Erosion Control Blanket and size of riprap (D50) needs to be specified.

- Lining type is based on slope of the ditch: unlined- slope equal to or less than 0.5%; ECB lined- slope 0.5%-3%; riprap lined—slope 3%-33%; plastic lined- slope 3%-33%. Dimensions shall be specified to ensure that the ditch adequately conveys runoff from a 2-year return period event for site conditions expected during the operation of the Control Measure. Ditches or drainageways conveying a 2-year flow rate exceeding 10 cfs shall require specific calculations and a design analysis by the Design Engineer.
- Runoff rate.

INSTALLATION AND MAINTENANCE

Key Installation and Maintenance Requirements:

- In locations where construction traffic must cross a DD, the GESC Manager shall install a temporary culvert that conveys the same flow as the ditch.
- If a DD fills in with sediment, the DD must be maintained to ensure a 2-year flow capacity.
- The GESC Manager shall inspect all DDs and shall ensure they are maintained in good operating condition.

11.7 EROSION CONTROL BLANKET (ECB)

Erosion Control Blanket (ECB) is a fibrous blanket of straw, jute, excelsior, or coconut material trenched in and staked down over prepared soil to reduce both wind and water erosion. ECB, or acceptable equivalent (See Appendix F, Flexible Growth Medium (FGM) detail), shall be required for any disturbed channel banks and all slopes steeper than 4:1. An ECB may be used for lining of a Diversion Ditch, or for temporary stabilization under a downspout (See Appendix D, Page 4). The Design Engineer shall indicate approximate limits of ECB, or equivalent, on the GESC Plan.

DESIGN

Parameters to be specified on the GESC Plan include the following items:

- Type of blanket (straw, straw-coconut, coconut, or excelsior); type of blanket shall be based on the shear stress associated with the design flow, as discussed below.
- Dimensions shall be specified to ensure that the blanket provides protection.
- Area (A) in square yards for each type of blanket.
- Location or dimension information.

All ECB shall have double sided netting. All ECB and netting should be made of 100% natural and biodegradable material and shall have a minimum product life of 2-years for channel bank applications and 12-month product life for slope applications.

ECB shall be specified based on the judgment of the Design Engineer, but at a minimum, blanket in drainageways shall be sized for the shear stress from a 2-year return period event for site conditions expected during the operation of the matting. Table 6-1 provides the maximum shear stress and velocity, based on unvegetated channel conditions, for allowable types of ECB.

A double-net straw or excelsior blanket shall be used for all slopes steeper than 4:1, outside of drainageways. Concave slope areas that may concentrate sheet flows as well as all other drainage channels (up to the top of the banks) shall require a double-net 70% straw / 30% coconut, double-net 100% coconut, or double-net 100% excelsior blanket based on the shear stress and velocity of the new or disturbed channel. The shear stresses and velocities

shown in Figure 6-1 shall be considered the maximum allowable values. Channels where velocities and stresses exceed those shown in Figure 6-1 shall require specific calculations and a design analysis by the Design Engineer.

Shear stress and velocity in ditches and drainageways may be calculated based on the following formulas: Shear stress (lbs/sf) = 62.4 * D * S, where:

D (ft) = maximum flow depth for the design (2-yr) storm event; S (ft/ft) = drainageway slope;

Velocity (ft/sec) = Q/A, where: Q (cfs) = flow rate for the (2-yr) storm event; A (sf)= cross-sectional area.

Table 6-1 Erosion Control Blanket Type

TYPE	COCONUT CONTENT	STRAW CONTENT	MIN. WEIGHT (lbs/sy)	MANNING'S N VALUE (varies with depth as shown)	ALLOWABLE MAX. SHEAR STRESS (lbs/sf)	ALLOWABLE MAX. VELOCITY (fps)
STRAW	0%	100%	0.5	0.018 for D>=2.0' 0.050 for D<=0.5'	Not allowed in drainage ways or diversion ditches	
STRAW- COCONUT	30% MIN.	70% MAX.	0.5	0.018 for D>=2.0' 0.050 for D<=0.5'	1.75	5.0
COCONUT	100%	0%	0.5	0.018 for D>=2.0' 0.050 for D<=0.5'	2.25	5.0
EXCELSIOR	NA	NA	0.7	0.028 for D>=2.0' 0.066 for D<=0.5'	2.00	5.0

For depths between 0.5 and 2.0-feet, the solution will be iterative, continuing until the depth corresponding to the Manning's N value is within 0.25-feet of the calculated depth. The maximum drainageway shear stress and velocity calculated using the above equations shall be less than the values indicated in Figure 6-1 for the type of blanket specified. This criterion is for temporary ditches and permanent channels designed to be grass lined. For permanent channels, the types of ECB shown shall be considered to comprise temporary erosion control only until vegetation can be established. The ECB shown herein shall be fabricated from 100 percent natural or biodegradable materials. ECB, as discussed in this section, is to be provided for temporary stabilization of permanent drainageways or roadside ditches that have been designed to be stable with grass or vegetative lining. The ECB is to provide erosion protection until the vegetation is established, and it is therefore an important component of an effective GESC Plan.

Figure 6-1. Erosion Control Blanket Design Criteria

		Shear Stress, lbs/sf									
		0.25	0.50	0.75	1.00	1.25	1.50	1.75	2.00	2.25	>2.25
Velocity, fps	1	All four types of ECB allowed				All but 100% straw allowed		Excelsior 100% and coconut allowed		100% coconut allowed	
	2										
	3										
	4										
	5										
	>5	Outside allowable range									

INSTALLATION AND MAINTENANCE

Key Installation and Maintenance Requirements:

- All ECB shall be double-sided netting and be made of 100% natural and biodegradable material; no plastic or other synthetic material, even if photodegradable, shall be allowed.
- Unless otherwise approved by SEMSWA in areas where ECB is shown on the plans, the GESC Manager shall place topsoil and perform final grading, surface preparation, and seeding below the blanket in accordance with the GESC Plan - Standard Notes and Details, Seeding and Mulching. Subgrade shall be smooth and moist prior to ECB installation and the ECB shall be in full contact with the subgrade; no gaps or voids shall exist under the ECB. Sufficient stakes will be used to keep blanket in contact with the soil to facilitate vegetation growth.
- Staking spacing dimensions on center shall be based on expected sheer velocities.
- Perimeter anchor trench shall be used at the outside perimeter of all ECB areas.
- Follow all manufacture installation specifications.
- Depending on location, 2 x 4 wedge stakes may be required to be removed prior to Final Close-out.
- The GESC Manager shall inspect ECB and maintain in good operating condition.

11.8 GRADE DIFFERENTIAL/CURB CUT BACK (GD/CCB)

A Grade Differential/Curb Cut Back (GD/CCB) Control Measure is a temporary sediment trap formed by excavation behind the curb/sidewalk/roadway. This Control Measure’s purpose is to intercept sediment-laden runoff from the site during construction and retain sediment on the lot. The hardscape (sidewalk, curb, or roadway) acts as a barrier to retain the stormwater long enough for the sediment to drop out before it leaves the site.

DESIGN

Design parameters to be specified on the GESC Plan include the following items:

- Location of the GD/CCB.

- Length (L) of the GD/CCB.
- Generally, the maximum allowable tributary drainage area per 50 lineal feet of GD/CCB is approximately 5,000 sq ft depending on the slope. Longer and steeper slopes require additional measures. When installed as perimeter control, it should be installed in a way that will not produce concentrated flows.
- Excavate soil from behind the curb, sidewalk, or roadway 3-4 inches down from the top of the hardscape and bring the soil back 3-4 feet from the hardscape. The depth and length of the excavated area may be increased if more sediment storage is needed or if the tributary area is greater than 50 lineal feet per 5,000 sq ft.
- Do not use in areas with 3:1 slopes or greater, or areas with concentrated flow.

INSTALLATION AND MAINTENANCE

Key Installation and Maintenance Requirements:

- The excavated area must be cleaned regularly as site conditions or rain events cause sediment deposition in the excavated area. Inspect this Control Measure to ensure the excavated area is at a minimum of 3-4 inches in depth and has a width of at a minimum of 3-4 feet.
- Remove accumulated sediment when berms or off-set cut reaches 1/3 capacity. Do not allow sediment to overflow onto curb or sidewalk.
- Do not store construction material within the GD/CCB excavated area.
- The GESC Manager shall inspect GD/CCB and maintain in good operating condition.

11.9 GROUT MIXING STATIONS (GMS)

A Grout/Mortar Mixing Station (GMS) area is a contained area to isolate grout/mortar mixing operations. A GMS Control Measure shall be provided when masonry work of any size or dimension is to be performed.

DESIGN

Design parameters to be specified on the GESC Plan include the following items:

- A note that the location of all proposed GMS operations will be determined in the field. The GESC Manager shall locate the GMS a minimum of 50 feet from storm drain inlets, open conveyance channels, drainage facilities and waterways.
- The proposed containment device shall be a minimum of 4" in height; earthen berm, concrete block enclosure, wood frame securely fastened around entire perimeter, or other approved method.
- A minimum 10 mil plastic liner covering entire mixing area shall be securely fastened to the raised containment device.

INSTALLATION AND MAINTENANCE

Key Installation and Maintenance Requirements:

- Area large enough to provide adequate containment of all mixing operations.
- Excavated material may be utilized in perimeter berm construction.
- All materials to be stored adjacent to the GMS shall be on pallets and be covered.
- All grout/mortar washout shall be contained in an approved CWA/GWA.

- At the end of construction, the liner and all grout/mortar waste residue shall be removed from the site and disposed of at an approved waste disposal site.
- The GESC Manager shall inspect the GMS and maintain in good operating condition.

11.10 INLET PROTECTION (IP)

Inlet Protection (IP) consists of a small, reinforced rock berm and cinder block frame placed in front of (but not completely blocking) a curb inlet or around an area inlet to reduce sediment in runoff entering the storm sewer system. At some point during a significant storm event, the Inspector may request that IP within the Right-of-Way be removed to allow for safe passage by vehicles. In this instance, sufficient time will be given to replace the IP that has been removed for safety reasons.

Storm sewer inlets on a site shall be provided with IP Control Measure. The GESC Plan shall specify whether the Control Measure is an area, sump, or continuous grade IP to be used in a particular location. The continuous grade curb sock IP is intended to trap sediment upstream of an inlet on a continuous grade street without causing any bypass of flow around the inlet. Sump and area IP is also designed to maintain inlet capacity after runoff flows over the wire-enclosed rock.

DESIGN

IP shall be shown on the GESC Plan at all street and area inlets. The GESC Plan shall indicate the type of IP, either sump or continuous grade for curb-opening inlets, or area IP. Determining the length of the reinforced rock berm to fit the inlet is the responsibility of the GESC Manager, as is providing temporary IP in accordance with the GESC Plan - Standard Notes and Details.

INSTALLATION AND MAINTENANCE

Key Installation and Maintenance Requirements:

- Interim configuration of IP in streets (before paving) shall be installed immediately after pouring of the inlet and the concrete has taken initial set.
- IP (after paving) shall be installed immediately after paving is placed.
- Wire mesh shall be twisted into a mesh with a maximum opening of 1.0-inch (commonly termed "Chicken Wire").
- Wire mesh shall be secured with wire ties at approximately 6-inch centers along all joints and at approximately 2-inch centers on ends of berm.
- Crushed rock shall be fractured face (all sides) and shall comply with gradation shown on the GESC Plan - Standard Notes and Details (1-1/2" minus). Recycled concrete may not be used.
- The top of reinforced rock berm shall allow for overtopping into the inlet.
- No gaps shall exist between sections of reinforced rock berms or cinder block frames.
- Tubular markers shall be placed on each end of IP located on streets where public access can occur.
- Reinforced rock berm or cinder block ends shall be placed tightly against curb face.
- IP is to remain in place until the upstream disturbed area is stabilized and grass cover approved, unless the Inspector approves earlier removal of IP.
- Maintain IP when there is evidence of significant sediment buildup.
- Replace IP if removed for public/vehicle safety during a significant storm event, as approved by the Inspector.

- The GESC Manager shall inspect IP and ensure it is maintained in good operating condition. More frequent inspections and repairs may be necessary during winter plowing conditions.

11.11 REINFORCED ROCK BERM (RRB)

A Reinforced Rock Berm (RRB) consists of a linear mass of gravel enclosed in wire mesh to form a porous filter, able to withstand overtopping. The berm is heavy and stable and promotes sediment deposition on its upstream side. Culvert inlets on a site shall be provided with an RRB.

DESIGN

Design parameters to be specified on the GESC Plan include the following items:

- Length (L) dimensions.
- Depth (D) dimensions.
- Location.
- If used in a Diversion Ditch or small drainageway, dimensions are to be specified to ensure that the RRB fits the drainageway cross section shape and provides adequate overtopping capacity. Multiple RRBs may be used as a Check Dam across swales and small drainageways for up to 20 acres of upstream drainage area.

INSTALLATION AND MAINTENANCE

Key Installation and Maintenance Requirements:

- Crushed rock shall be fractured face (all sides) and shall comply with gradation shown in the GESC Plan - Standard Notes and Details (1-1/2" minus). Recycled concrete may not be used.
- Wire mesh shall be wire twisted into a mesh with a maximum opening of 1.0-inch ("Chicken Wire").
- Wire mesh shall be secured wire ties at approximately 6-inch centers along all joints and at approximately 2-inch centers on ends of berm.
- Sediment accumulated upstream of RRB shall be removed when the sediment depth upstream of filter is 50% of the height or if the rock becomes further clogged.
- The GESC Manager shall inspect RRB and ensure it is maintained in good operating condition.

11.12 SEDIMENT BASIN (SB)

A Sediment Basin (SB) is an impoundment that captures sediment-laden runoff and releases it slowly, providing prolonged settling times to capture coarse and fine-grained soil particles. Runoff from disturbed drainage areas exceeding 1 acre shall be treated in a SB. Runoff from disturbed areas less than 1 acre may be treated in a Sediment Trap.

DESIGN

Design parameters shall be specified on the GESC Plan and include the following items:

- Location.
- Outlet release design based on Table 6-2 below.
- The SB design shown on the GESC Plan - Standard Notes and Details provided in Appendix F shall be used for any disturbed drainage area greater than 1 acre. The standard SB is appropriate for use for disturbed

drainage areas up to 15 acres. For drainage areas greater than 15 acres, an alternate design approach will be required as approved by the Inspector and justified with calculations included within the report.

- The SB discharge point must be to a stabilized area that does not drain back into a disturbed area.

Sizing information for the SB design (based on providing a minimum initial storage volume equal to 1,800 cubic feet per upstream acre) shall be determined from Table 6-2. As shown on the GESC Plan - Standard Notes and Detail sheets, the standard SB features a pipe outlet drilled with a single column of orifice holes. The hole diameter shown in Table 6-2 will drain the upper 1.5 feet of the SB in about 40 hours.

Table 6-2. Sizing Information for Standard Sediment Basin

Upstream Drainage Area (rounded to nearest acre), (ac)	Basin Bottom Width (W), (ft)	Spillway Crest Length (CL), (ft)	Hole Diameter (HD), (in)
1	16	2.0	7/16
2	22	4.0	5/8
3	27	6.0	3/4
4	31	8.0	7/8
5	35	10.0	1.0
6	38	12.0	1 1/8
7	41	14.0	1 1/4
8	44	16.0	1 1/4
9	47	18.0	1 3/8
10	49	20.0	1 3/8
11	52	22.0	1 1/2
12	54	24.0	1 1/2
13	56	26.0	1 5/8
14	59	28.0	1 5/8
15	61	30.0	1 3/4

Outlet facilities for extended detention basins that provide a drain time of 40-hours may be used as the SB outlet, with proper outlet Control Measures in place.

INSTALLATION AND MAINTENANCE

Key Installation and Maintenance Requirements:

- A gravel pack of rock around the pipe outlet shall be provided. The rock needs to be sized appropriately to not clog the outlet.
- Sediment accumulated within the SB shall be removed when the design storage volume is no more than 1/3 filled with sediment.

- The SB volume shall be maintained to the design intent and kept in a maintained condition until vegetation in upstream watershed is fully established and accepted.
- Trash and debris shall be removed from the SB to prevent clogging at the outlet.
- The GESC Manager shall inspect the SB Control Measure and shall ensure it is maintained in good operating condition.

11.13 SEDIMENT CONTROL LOG (SCL)

A Sediment Control Log (SCL) consists of a cylindrical bundle of excelsior, straw, or coconut material designed to form a semi-porous filter, able to withstand overtopping.

DESIGN

Design parameters to be specified on the GESC Plan shall include the following items:

- Location of the SCL.
- Length (L) of the SCL.
- Generally, the maximum allowable tributary drainage area per 50 lineal feet of SCL, installed along the contour, is approximately 5,000 sq ft depending on the slope. Longer and steeper slopes require additional measures. This recommendation only applies to SCL installed along the contour. When installed for other uses, such as perimeter control, it should be installed in a way that will not produce concentrated flows. For example, a "J-hook" installation may be appropriate to force runoff to pond and evaporate or infiltrate in multiple areas, rather than concentrate and cause erosive conditions parallel to the SCL.
- SCL shall not be used across swales or drainageways.
- In most cases, SCL shall be located on the contour. SCL may be shown running up or down slight slopes.

INSTALLATION AND MAINTENANCE

SCL shall be staked into the ground to promote sediment deposition on its upstream side and a reduction in flow velocities.

Key Installation and Maintenance Requirements:

- The SCL shall be trenched into the ground per manufacturer instructions.
- SCL shall be maintained when upstream sediment reaches 50%.
- The GESC Manager shall inspect and ensure SCL is maintained in good operating condition.

11.14 SEDIMENT TRAP (ST)

A Sediment Trap (ST) consists of a riprap berm with a small upstream basin that acts to trap coarse sediment particles. It may be used for upstream disturbed areas less than 1 acre. Runoff from disturbed areas exceeding 1 acre shall be treated in a Sediment Basin.

DESIGN

Design parameters shall be specified on the GESC Plan and include the following items:

- Location, length (L) and width (W) dimensions. A ST may be used for upstream disturbed areas less than 1 acre. ST dimensions shall be specified to provide a storage volume equal to 1,800 cubic feet per upstream acre.
- ST designed in series shall require a specific calculation and a design analysis by the Design Engineer.
- Overtopping must occur on stabilized surfaces, to include well-vegetated areas, riprap, or pavement.

INSTALLATION AND MAINTENANCE

Key Installation and Maintenance Requirements:

- The top of the earthen berm shall allow for overtopping at the crest.
- The ends of the riprap outlet structure shall be higher than the center of the outlet structure to allow for overtopping at the crest.
- Sediment accumulated within in the ST shall be removed when volume is reduced by approximately 50%.
- The GESC Manager shall inspect the ST and ensure it is maintained in good operating condition.

11.15 SEEDING AND MULCHING (SM)

Seeding and Mulching (SM) consists of drill seeding disturbed areas with the approved SEMSWA seed mix and crimping in straw mulch to provide immediate protection against water and wind erosion and, as the grass cover becomes established, to provide long-term stabilization of exposed soils.

For permanent stabilization (i.e. final grading is completed), the GESC Permit Program requires that the disturbed area be permanently seeded and mulched. If the time of year does not allow for seeding operations to be effective, the Permittee may be granted an extension on the seeding requirement, however; mulching of the area will be required. The Permittee will be required to seed and mulch the disturbed area by the date that is provided by the Inspector on the inspection report.

DESIGN

Design parameters to be specified on the GESC Plan include the following items:

- Area (A) in acres to be SM.
- Type of seed mix.

All projects include a seed mix recommendation provided by a Landscape Architect with sufficient knowledge of the project. If a Landscape Architect does not provide a seed mix, then SEMSWA's standard seed mix shall be specified. The main requirements include the following:

- Existing topsoil shall be stripped to a depth of six inches (unless otherwise approved) from areas to be disturbed. The stripped topsoil shall be stockpiled during grading operations, then replaced to a depth of at least six inches in all areas to be seeded. If quantities of on-site topsoil are inadequate to provide a replaced depth of six inches, the Permittee/Contractor will have to import topsoil or amend/condition the soil as approved by the Inspector. All disturbed areas are to be ripped prior to placing topsoil. Topsoil shall be thoroughly loosened prior to seeding to a depth of at least six inches.
- Seeding shall be accomplished using a drill seeder at a depth of seeding not less than 1/4-inch and not more than 3/4-inch and at the rates specified in the GESC Plan - Standard Notes and Details. In small areas that are impossible to drill seed, the Permittee/Contractor, with the Inspector's prior approval, may hand

broadcast seed at twice the drilled rate, lightly rake to cover the seed, and crimp mulch. Information on seed types in the standard seed mixes is provided in Appendix F

- Straw mulch shall be applied at a rate of 4,000-pounds per acre and mechanically crimped into the soil and tackified where needed. In places where straw mulch cannot be mechanically crimped due to site constraints, Hydraulic mulch may be considered, with approval from the Inspector.

INSTALLATION AND MAINTENANCE

Key Installation and Maintenance Requirements:

- All areas to be seeded and mulched shall have native topsoil or appropriately conditioned soil spread to a depth of at least 6-inches (loose depth).
- All disturbed areas shall be loosened (tilled) to a depth of 6-inches prior to spreading topsoil.
- The top 6-inches of the seed bed shall be generally free of rocks, woody debris and soil clods.
- Stockpiles/areas that are being temporarily seeded do not require topsoil prior to seeding and mulching.
- Seed shall be applied using a mechanical drill to a depth of not less than 1/4-inch and not more than 3/4-inch. Row spacing shall be no more than 6-inches. Material used for mulch shall consist of long-stemmed straw. At least 50-percent of the straw, by weight, shall be as long in length as possible. Mulch shall be applied and mechanically anchored to a depth of at least 3-inches at a rate of 4,000-pounds of straw/acre.
- Copies of seed tickets shall be provided to the Inspector, upon request.
- Temporary Irrigation is highly encouraged to assist with growth of vegetation.
- Seeded and mulched areas shall be inspected for required coverage monthly, until the site reaches final acceptance. Repairs and re-seeding and mulching shall be undertaken for any areas failing to meet the required coverage until final acceptance. Required coverage is defined as 70% of the existing/preconstruction condition, free of eroded areas, and free from infestation of noxious weeds.
- Tackifier shall be utilized to help with straw displacement.

11.16 SILT FENCE (SF)

Silt Fence (SF) or Reinforced Silt Fence (SFR) is a temporary sediment barrier constructed of woven fabric stretched across supporting posts. The bottom edge of the fabric is placed in an anchor trench that is backfilled with compacted soil.

DESIGN

Design parameters to be specified on the GESC Plan include the following items:

- Location of SF.
- Length (L) in linear feet of SF.
- SF works most effectively when placed relatively level, on the contour, to capture and filter approaching sheet flow. It is not suited for concentrated flow or for large upstream drainage areas. The following criteria shall apply to the use of SF:
 - SF shall not be used across swales or drainageways.
 - SF shall be located on the contour. SF may be shown running up or down slight slopes.
 - The average upslope length of the area draining to an individual section of SF shall not exceed 100 disturbed feet and the total area draining to a section of SF shall not exceed 10,000 square feet of disturbed area.

- SF located at the toe of a slope should be placed a minimum of five feet offset from the toe to allow for maintenance activities.
- SF used to protect the drainage way from upland construction activities shall be wire-backed.

INSTALLATION AND MAINTENANCE

Key Installation and Maintenance Requirements:

- The bottom portion of the SF shall be trenched in and compacted per the GESC Plan - Standard Notes and Detail. SF installation machines that use trenching or slicing may be utilized to install SF.
- Sediment accumulated upstream of SF shall be removed when the upstream sediment reaches 25%.
- SF near the roadway is the responsibility of the Permittee/Contractor to maintain, even if damaged from public snow removal operations.
- The GESC Manager shall inspect SF and ensure it is maintained in good operating condition.

11.17 SLOPE INTERCEPT DITCH (SID)

A Slope Intercept Ditch (SID) is a small earth channel with accompanying earthen berm cut in on the contour used to check stormwater surface flows from leaving a construction site and to prevent run-on of stormwater surface flows from undisturbed areas contiguous with the construction site.

DESIGN

Design parameters to be specified on the GESC Plan include the following items:

- Location and length of each SID.
- May be used in place of Silt Fence and Sediment Control Logs, as appropriate.

INSTALLATION AND MAINTENANCE

Key Installation and Maintenance Requirements:

- Material cut out of the SID should form a compacted berm adjacent to, on the construction side of the SID.
- Minimum SID depth shall be 10 inches.
- Compacted berm from SID spoils shall be a minimum 10 inches in height.
- Sediment accumulated in the SID shall be removed when half-full. Sediment shall be placed on and compacted with the adjacent berm.
- The GESC Manager shall inspect all SID and shall ensure they are maintained in good operating condition.

11.18 STABILIZED STAGING AREA (SSA)

A Stabilized Staging Area (SSA) consists of stripping topsoil and spreading a layer of angular granular material in the area to be used for a trailer, equipment, parking, storage, unloading and loading.

An SSA shall be provided near the main access point and ideally connected to the Vehicle Tracking Control.

DESIGN

Design parameters to be specified on the GESC Plan include the following:

- Location of SSA.
- Approximate area (A) in square yards of the SSA.

Gravel or road base may be used for the SSA. Recycled asphalt shall not be used. Recycled concrete may be used upon SEMSWA approval.

INSTALLATION AND MAINTENANCE

Key Installation and Maintenance Requirements:

- SSA shall be large enough to contain equipment, parking, storage, and unloading and loading operations.
- SSA shall consist of a minimum thickness of 3 inches of angular granular material.
- The GESC Manager shall inspect the SSA and ensure it is maintained in good operating condition.

11.19 STREET SWEEPING (SS)

Street Sweeping consists of cleaning mud and other debris which is tracked onto impervious surface at a construction site. Street sweeping shall be used for incidental tracking and is not to be used as a perimeter Control Measure or as the sole Control Measure. Removing all tracked mud from the streets reduces or eliminates sediment transport to downstream structures and receiving water.

Any damage from sweeping public streets may require repair to the street and shall be paid for by the Permittee.

DESIGN

No design is required for SS.

INSTALLATION AND MAINTENANCE

Key Installation and Maintenance Requirements:

- Any mud tracked onto the street shall be cleaned using a vacuum-type street sweeper, a brush-type street sweeper with dust control, or manually using shovels and brooms.
- Ensure all appropriate permits for sweeping public streets are obtained.
- Streets shall not be washed with water at any time unless all water is contained and collected.
- The GESC Manager shall inspect streets and ensure they are free of dirt and debris.

11.20 SURFACE ROUGHENING (SR)

Surface Roughening (SR) consists of creating a series of grooves or furrows on the contour in all disturbed, graded areas to trap rainfall and reduce the formation of rill and gully erosion. This is an effective Control Measure that can be used to control runoff for areas of the site and provides a layered Control Measure approach, or treatment train approach to limit runoff and sediment transport.

DESIGN

Since SR is to be performed for all disturbed, graded areas on a site, the location of SR does not need to be indicated on the plan.

INSTALLATION AND MAINTENANCE

Key Installation and Maintenance Requirements:

- Disturbed surfaces shall be roughened using ripping or tilling equipment on the contour or tracking up and down a slope using equipment treads.
- The GESC Manager shall inspect SR and shall ensure it is maintained in good operating condition.

11.21 TEMPORARY SLOPE DRAIN (TSD)

A Temporary Slope Drain (TSD) is a small culvert, plastic rundown or riprap rundown to convey runoff down a slope or channel bank to reduce the occurrence of rill and gully erosion.

A TSD shall be used to convey runoff down a channel bank or slope to the bottom of a drainageway. When a ditch, constructed to convey runoff, intersects a slope or channel bank, a TSD, consisting of pipe, plastic, or riprap, shall be required to convey diverted water from the DD down the slope or channel bank.

DESIGN

Design parameters to be specified on the GESC Plan include the following items:

- Type of TSD (pipe, riprap lined, or plastic lined).
- Location and length (L) in linear feet.
- "D" dimension and "D50" size.
- Dimensions are to be specified to ensure that the TSD provides capacity equal to a 2-year return period event for site conditions expected during the operation of the slope drain.

INSTALLATION AND MAINTENANCE

Key Installation and Maintenance Requirements:

- An energy dissipater shall be placed at the outfall of the TSD.
- The GESC Manager shall inspect the TSD and ensure it is maintained in good operating condition.

11.22 TEMPORARY STREAM CROSSING (TSC)

A Temporary Stream Crossing (TSC) consists of culverts covered with rock to allow construction equipment to cross a stream. Excavation of the existing channel and disturbance is to be kept to a minimum.

Crossing drainageways with construction equipment requires a TSC. Appropriate Control Measures shall still be used to keep sediment from entering the drainageway. Any Control Measure placed within a drainageway must have the appropriate permits from the Corps, and SEMSWA. In addition, SEMSWA may require a Water Control Plan.

DESIGN

Design parameters to be specified on the GESC Plan include the following items:

- Location of TSC.
- Length (L), height (Y), overtopping depth (H), diameter (D) and number of culverts.

The type of TSC is based on the presence of baseflow and the shape of the channel. If there is any baseflow present, or the channel is relatively deep and narrow, a culvert crossing shall be used. For temporary culvert crossings, the Design Engineer shall specify pipe class, minimum cover, etc. to ensure that the culverts will bear the loads associated with the type of vehicles that may use the crossing. The structural capacity of the crossing may require specific calculations and a design analysis by the Design Engineer.

INSTALLATION AND MAINTENANCE

Key Installation and Maintenance Requirements:

- Sediment accumulated upstream of TSC shall be removed when the sediment depth upstream of crossing is 50% or greater of the culvert opening.
- The GESC Manager shall inspect TSC and ensure it is maintained in good operating condition.

11.23 VEHICLE TRACKING CONTROL (VTC)

Vehicle Tracking Control (VTC) consists of a crushed rock pad that is 12 inches thick at all exit points for a site. VTC is intended to strip mud from tires prior to vehicles and equipment leaving the construction site.

VTC shall be provided at all exit points at the site. The number of access points at a construction site shall be minimized.

DESIGN

Design parameters to be specified on the GESC Plan include the following:

- Location of all VTCs.

INSTALLATION AND MAINTENANCE

Key Installation and Maintenance Requirements:

- VTC shall be installed at every access point from the construction site.
- VTC shall consist of hard, dense, durable stone, angular in shape and resistant to weathering. Rounded stone or boulders will not be acceptable. The stones shall not be smaller than 3-inches in size.
- Curb ramps of any type are not allowed in the curb section.
- VTC must be maintained whenever tracking is evident, or at the discretion of the SEMSWA Inspector.
- Construction Fence (CF) will be required along each side of the VTC.
- The GESC Manager shall inspect the VTC and ensure it is maintained in good operating condition.

11.24 VEHICLE TRACKING CONTROL WITH WHEEL WASH (WW)

Vehicle Tracking Control with Wheel Wash (WW) does not need to be specified. It shall be used if specifically required by the Inspector. Typically, if vehicle tracking onto public streets is a repetitive violation, a WW will be required by the Inspector.

DESIGN

No design is required.

INSTALLATION AND MAINTENANCE

WW consists of a gravel and riprap pad at the main exit point for the site with an adjacent wash water/sediment trap. If a Contractor is required to implement this Control Measure, each wheel of all vehicles coming into contact with dirt or mud shall be cleaned using a high-pressure washer prior to the vehicle leaving the site.

12 AUTHORIZATION OF THE GESC MANUAL

The *GESC Manual* is authorized and approved by the SEMSWA Board of Directors.

Appendix A: GESC Contact Information

(Information is subject to change)

SEMSWA

Phone: 303-858-8844

Fax: 303-267-9550

Email: semswamain@semswa.org

Web: www.SEMSWA.org

City of Centennial

Community Development
13133 East Arapahoe Road
Centennial, Colorado 80111

Phone: 303-754-3308

Fax: 720-488-0933

Web: www.centennialco.gov

Other

Colorado Department of Public Health and
Environment

Water Quality Control Division

Phone: 303-692-3500

Web: www.colorado.gov/cdphe

U.S. Army Corps of Engineers, Omaha District
Tri-Lakes Project Office

Phone: 303-979-4120

Fax: 303-979-0602

United States Department of the Interior
Fish and Wildlife Division

Phone: 303-326-7400

Mile High Flood District

Phone: 303-455-6277

Fax: 303-455-7880

Web: www.mhfd.org

Federal Emergency Management Agency
Region VIII

Phone: 303-235-4800

Fax: 303-235-4976

Web: www.fema.gov

Cherry Creek Basin Water Quality Authority

Phone: 303-779-4525

Fax: 303-773-2050

Web: www.cherrycreekbasin.org

Arapahoe County Weed Control Specialist
Arapahoe County Government - Public Works
and Development

Phone: 720-874-6713

Fax: 303-794-3201

Web: www.co.arapahoe.co.us

Appendix B: Early Grading Form Letter

HOLD HARMLESS LETTER FOR EARLY START OF GRADING

Land Development Engineering Manager
Southeast Metro Stormwater Authority (SEMSWA)
7437 South Fairplay Street
Centennial, CO 80112-4486

- Planning Commission or City Council Approval
- City Planning Director Approval

Subject: Early Start (Grading Only) for:

Project No: _____

Project Name: _____

To Whom It May Concern,

We are requesting an early start on implementing the Grading, Erosion and Sediment Control (GESC) Plan(s) for the project. The Construction Drawings, Phase III Drainage Report, and/or other technical documents have not yet been approved by SEMSWA or the City of Centennial, as applicable. In order to start this work, we understand that the GESC Plan(s) must be complete, submitted to SEMSWA for review and approval, the GESC Permit complete, submitted, and approved, and the collateral posted. We agree that no impervious area will be created at the site as part of this early grading.

We further understand that any work that occurs under this Early Grading Hold Harmless Letter will be at the risk of the owner. Specifically, any changes required for the GESC Plan(s) or GESC Permit resulting from approved Construction Drawings, or other applicable documents, will be the responsibility of the owner. We acknowledge that SEMSWA will not be held responsible for those changes or the cost of those changes. We shall be responsible for all the costs associated with any changes that may be required under the GESC Plan(s), Report and/or Permit. SEMSWA shall not be responsible for any costs.

I have read the GESC Manual, specifically the GESC Permit Policies, and understand that the owner assumes all of the risk of completing grading prior to approval of development plans for a site. Approval of the GESC Plan(s) and Report does not imply approval of other engineering concepts or documents associated with a submittal. Prior to the issuance of the approved GESC Permit, we will submit the required collateral for the revegetation/stabilization of the site and/or all of the erosion and sediment control measures that are required to be installed per the GESC Plan for the development site.

Sincerely,

(Owner's Name, Title, and Signature)

Date: _____

Appendix C: Engineer's Cost Estimate - Initial/Interim

GESC Permit

Engineer's Cost Estimate Spreadsheet for Initial and Interim Control Measures

Note: *Initial* and *Interim* Control Measures shall be added together for the Cost Estimate

Project Name: _____

Date: _____

No.	Control Measures	ID	Unit	Installation Unit Cost	Initial/Interim Quantity	Initial/Interim Cost
1	Check Dam	CD	LF	\$ 24.00		\$ -
2	Compost Blanket	CB	SF	\$ 0.36		\$ -
3	Compost Filter Berm	CFB	LF	\$ 2.00		\$ -
4	Concrete Washout Area	CWA	EA	\$ 100.00		\$ -
5	Construction Fence	CF	LF	\$ 2.00		\$ -
6	Construction Markers	CM	LF	\$ 0.20		\$ -
7	Dewatering	DW	EA	\$ 600.00		\$ -
8	Diversion Ditch	DD	LF	\$ 1.60		\$ -
9	Erosion Control Blanket	ECB	SY	\$ 5.00		\$ -
10	Inlet Protection	IP	EA	\$ 200.00		\$ -
11	Reinforced Check Dam	RCD	LF	\$ 36.00		\$ -
12	Reinforced Rock Berm	RRB	LF	\$ 9.00		\$ -
13	RRB for Culvert Protection	RRC	LF	\$ 9.00		\$ -
14	Sediment Basin (Based on area tributary to the pond)	SB	AC	\$ 1,000.00		\$ -
15	Sediment Control Log	SCL	LF	\$ 2.00		\$ -
16	Sediment Trap	ST	EA	\$ 600.00		\$ -
17	Seeding & Mulching (Less than 10 Acres)	SM	AC	\$ 2,500.00		\$ -
	(Greater than 10 Acres)	SM	AC	\$ 1,500.00		\$ -
18	Silt Fence	SF	LF	\$ 2.00		\$ -
19	Stabilized Staging Area	SSA	SY	\$ 2.00		\$ -
20	Surface Roughening	SR	AC	\$ 600.00		\$ -
21	Temporary Slope Drain	TSD	LF	\$ 30.00		\$ -
22	Temporary Stream Crossing	TSC	EA	\$ 1,000.00		\$ -
23	Terracing	TER				\$ -
24	Vehicle Tracking Control	VTC	EA	\$ 1,000.00		\$ -
25	VTC with Wheel Wash	WW	EA	\$ 1,500.00		\$ -
26	Mobilization (required on all projects)	MB	LS	\$ 5,000.00	1	\$ 5,000.00
27	Pond Maintenance/Sediment Removal (Based on area tributary to the pond)	PM	AC	\$ 1,000.00		\$ -
28	Rock/Curb Socks	CS	LF	\$ 16.00		\$ -
29	Street Maintenance (Required on all projects. Based on lane miles of streets within project and frontage)	SM	LM	\$ 500.00		\$ -

Total Cost of **Initial & Interim Control Measures**

\$ 5,000.00

Appendix C: Engineer's Cost Estimates - Final

GESC Permit

Engineer's Cost Estimate for Final Control Measures

Note: Final Control Measures shall be added together for the Cost Estimate

Project Name: _____

Date: _____

No.	Control Measures	ID	Unit	Installation Unit	Final Quantity	Final Cost
1	Check Dam	CD	LF	\$ 24.00		\$ -
2	Compost Blanket	CB	SF	\$ 0.36		\$ -
3	Compost Filter Berm	CFB	LF	\$ 2.00		\$ -
4	Concrete Washout Area	CWA	EA	\$ 100.00		\$ -
5	Construction Fence	CF	LF	\$ 2.00		\$ -
6	Construction Markers	CM	LF	\$ 0.20		\$ -
7	Dewatering	DW	EA	\$ 600.00		\$ -
8	Diversion Ditch	DD	LF	\$ 1.60		\$ -
9	Erosion Control Blanket	ECB	SY	\$ 5.00		\$ -
10	Inlet Protection	IP	EA	\$ 200.00		\$ -
11	Reinforced Check Dam	RCD	LF	\$ 36.00		\$ -
12	Reinforced Rock Berm	RRB	LF	\$ 9.00		\$ -
13	RRB for Culvert Protection	RRC	LF	\$ 9.00		\$ -
14	Sediment Basin (Based on area tributary to the pond)	SB	AC	\$ 1,000.00		\$ -
15	Sediment Control Log	SCL	LF	\$ 2.00		\$ -
16	Sediment Trap	ST	EA	\$ 600.00		\$ -
17	Seeding & Mulching (Less than 10 Acres)	SM	AC	\$ 2,500.00		\$ -
	(Greater than	SM	AC	\$ 1,500.00		\$ -
18	Silt Fence	SF	LF	\$ 2.00		\$ -
19	Stabilized Staging Area	SSA	SY	\$ 2.00		\$ -
20	Surface Roughening	SR	AC	\$ 600.00		\$ -
21	Temporary Slope Drain	TSD	LF	\$ 30.00		\$ -
22	Temporary Stream Crossing	TSC	EA	\$ 1,000.00		\$ -
23	Terracing	TER				\$ -
24	Vehicle Tracking Control	VTC	EA	\$ 1,000.00		\$ -
25	VTC with Wheel Wash	WW	EA	\$ 1,500.00		\$ -
26	Mobilization (Required on all projects)	MB	LS	\$ 5,000.00	1	\$ 5,000.00
27	Pond Maintenance/Sediment Removal (Based on area tributary to the pond)	PM	AC	\$ 1,000.00		\$ -
28	Street Maintenance (Required on all projects. Based on lane miles of streets within project and	SM	LM	\$ 500.00		\$ -
29	Other					\$ -

Total Cost of **Final Control Measures**

\$ 5,000.00

Appendix D: Example Single-Family Individual Lot GESC Plans

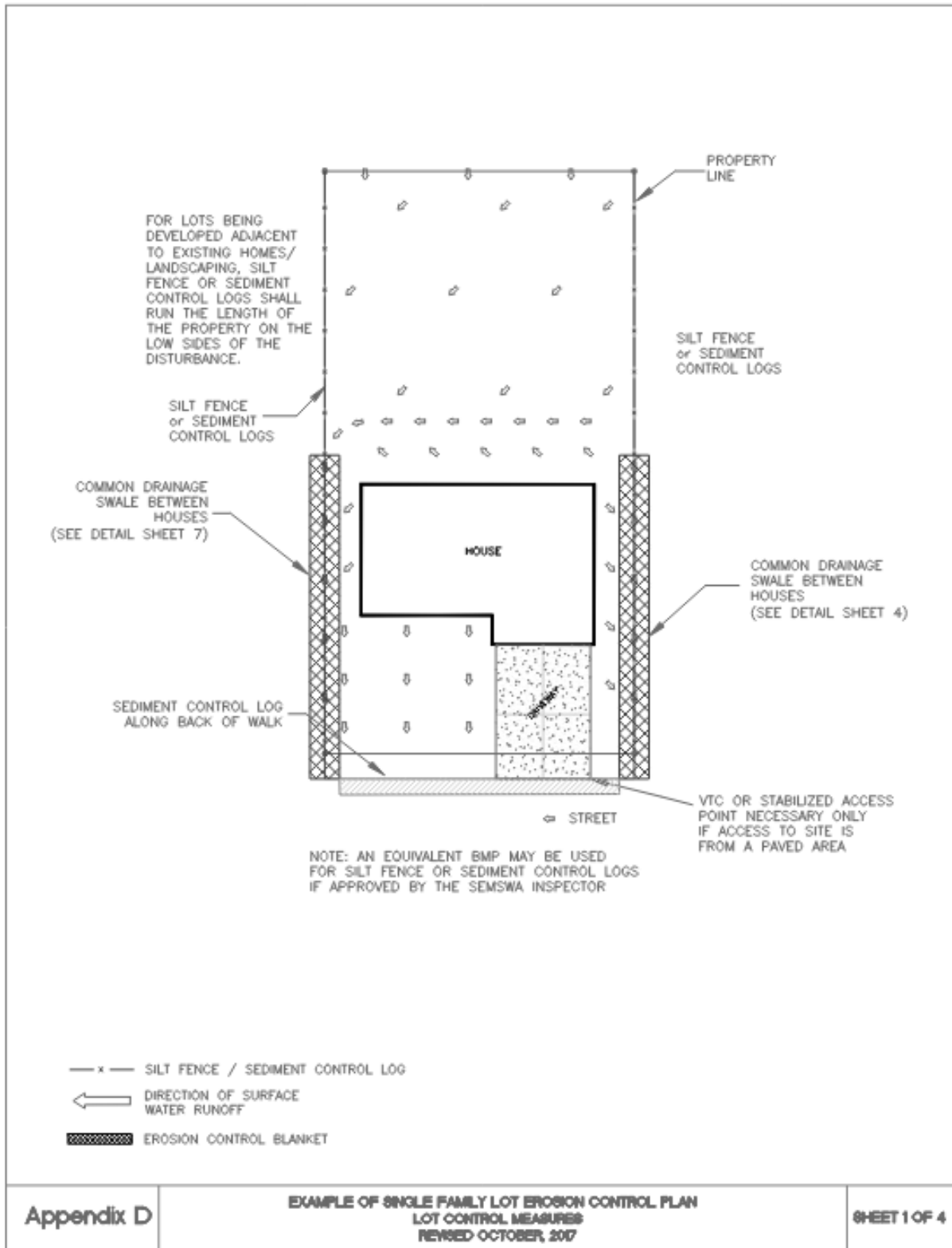

Appendix D: Example Single-Family Individual Lot GESC Plans

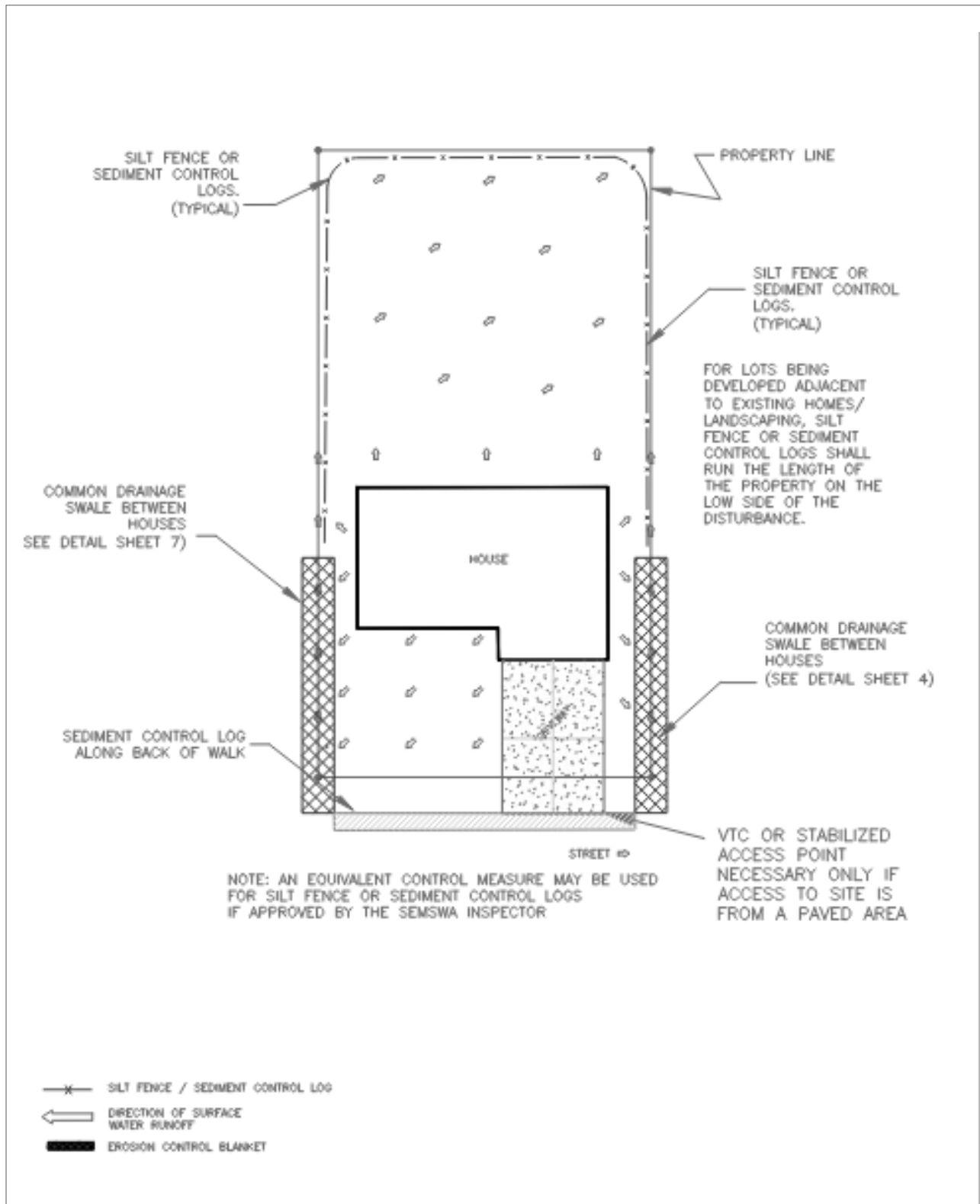

Appendix D: Example Single-Family Individual Lot GESC Plans

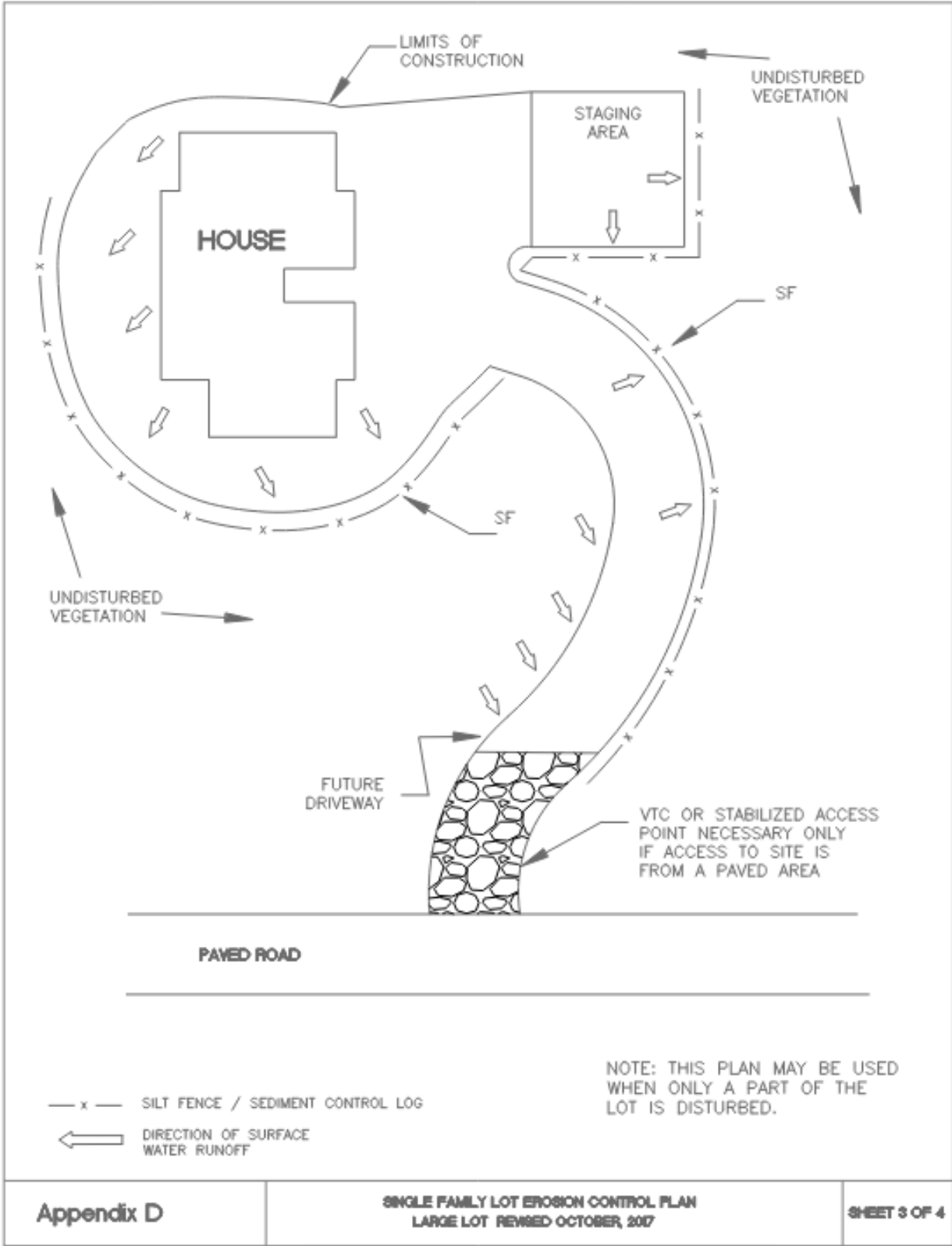

Appendix D: Example Single-Family Individual Lot GESC Plans

COMMON DRAINAGE SWALE AND DOWNSPOUT PROTECTION DETAIL (BETWEEN HOUSES)

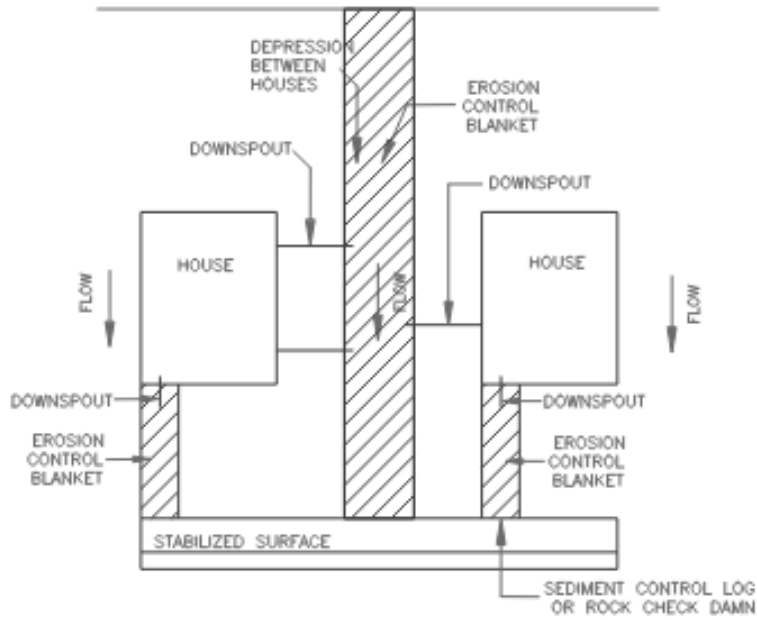

NOTE: DETAIL MUST BE IMPLEMENTED WHEN DOWNSPOUTS ARE INSTALLED ON HOUSE(S)

EXAMPLE: DOWNSPOUT PROTECTION DETAIL

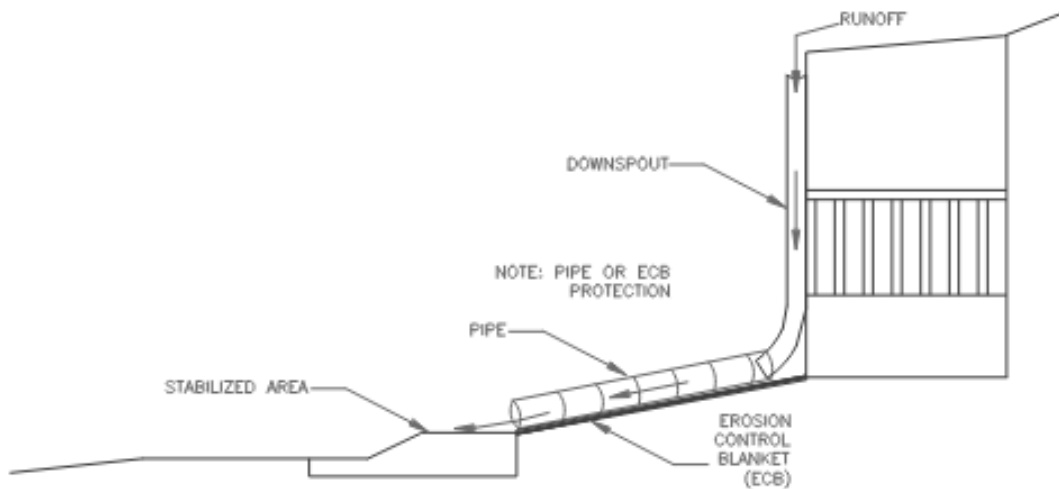

Appendix E: GESC Plan and Report Checklist

This checklist must be filled out and included in the Appendix of the GESC Report

Yes	No	N/A	GESC Requirements
I. GESC REPORT			
			A. COVER PAGE
			1. Project name and complete address
			2. Contact information of the applicant
			3. Contact information of the Professional Engineer preparing (or supervising the preparation of) the GESC Documents
			B. SIGNATURE PAGE
			1. The following note (above Certification Statements)
			<p>“This <i>Grading, Erosion and Sediment Control (GESC)</i> document has been placed in the project file for this project and appears to fulfill the latest version of the <i>Grading, Erosion and Sediment Control Manual</i>. Additional grading, erosion and sediment Control Measures may be required of the owner or his/her agents, due to unforeseen erosion problems or if the submitted plan does not function as intended. The requirements of this GESC document shall run with the land and be the obligation of the land owner, or his/her designated representative(s) until such time as the plan is properly completed, modified or voided.”</p>
			2. Landowner Certification Statement (For landowner/ authorized agent acknowledging the review and acceptance of responsibility)
			<p>“I hereby certify that the Grading, Erosion, and Sediment Control Measures for (Name of Subdivision/Development/address) shall be constructed according to the design presented in this document. I understand that additional erosion control, sediment control and water quality enhancing measures may be required of the owner and his or her agents due to unforeseen pollutant discharges or if the submitted plan does not function as intended. The requirements of the plan shall be the obligation of the land owner and/or his successors or heirs; until such time as the plan is properly completed, modified or voided.”</p> <p>Owner or Authorized Agent _____ Authorized Signature _____</p>
			3. Professional Engineer Certification Statement (for the professional engineer acknowledging responsibility for the preparation of the GESC documents)
			<p>“I hereby attest that this Grading, Erosion, and Sediment Control (GESC) document for (name of subdivision/development) has been prepared by me or under my direct supervision, and to the best of my knowledge and ability has been prepared in accordance with the latest version of the GESC Manual. The signature and stamp affixed hereon certifies that this GESC document was prepared in accordance with the required regulations and criteria; however, the stamp and signature does not certify or guarantee future performance of the execution of the plan by the contractor. The contractor is responsible for executing the</p>

Yes	No	N/A	GESC Requirements
			<p>construction work according to the information set forth in the plan and in accordance with all applicable requirements.”</p> <p>Registered Professional Engineer _____ State of Colorado No. _____ Affix Seal w/date</p>
			C. GESC REPORT
			1. Project Description
			a. Describe the nature and purpose of the land disturbing activity
			b. Total area of the site
			c. Total area of disturbance
			d. Project location – including township, range, section and quarter-section (or the latitude and longitude of the approximate center of the project)
			e. Vicinity Map
			2. Existing Site Conditions
			a. Description of the existing topography, vegetation and drainage (Pictures of the existing vegetation are encouraged)
			b. Description of any wetlands on the site
			c. Description of any other unique features of the property.
			3. Adjacent Areas - Description of neighboring areas such as streams, lakes, Floodplain, residential areas, roads, etc., which might be affected by the land disturbance.
			4. Soils - A brief description of the soils on the site including information on soil type and names, mapping unit, erodibility, permeability, hydrologic soil group, depth, texture, and soil structure. This information may be obtained from the soil report for the site or the applicable Soil Survey prepared by the Natural Resources Conservation Service (NRCS). Include relevant portions of soil report or NRCS Soil Survey in an appendix.
			5. Area and Volumes
			a. An estimate of the quantity (in cubic yards) of excavation and fill involved (attempting to achieve an earthwork balance)
			b. Haul road information
			c. Surface area (in acres) of the proposed disturbance
			6. Control Measures – A summary of the Control Measures selected, designed, installed, implemented and maintained on site, including the timing of installation and removal.
			a. All sediment and erosion Control Measures as shown on GESC Plans.
			b. Land disturbance and storage of soils
			c. Vehicle Tracking
			d. Loading and unloading operations

Yes	No	N/A	GESC Requirements
			e. Outdoor storage or construction site materials, building materials, fertilizers, and chemicals
			f. Bulk storage of materials
			g. Vehicle and equipment maintenance and fueling
			h. Significant dust or particulate generating processes
			i. Routine maintenance activities involving fertilizers, pesticides, detergents, fuels, solvents and oils
			j. Concrete truck chute and associated fixtures and equipment washing
			k. Dedicated asphalt and concrete batch plants
			l. Other areas or operations where spills can occur
			m. Other non-stormwater discharges including construction dewatering not covered under the Construction Dewatering Discharges General Permit and wash water that may contribute pollutants to the MS4
			7. Permanent Stabilization - A brief description, including applicable specifications, of how the site will be stabilized after construction is complete
			8. Stormwater Management Considerations - Explain how stormwater runoff from and through the site will be handled during construction
			9. Maintenance - Any special maintenance requirements over and above what is identified in the Standard Notes and Details.
			10. Calculations – include in an appendix
			a. Sediment Basin Design Calculations
			b. Diversion Ditch Calculations
			c. Erosion Control Blanket/Matting selection
			D. ENGINEERS COST ESTIMATE
			A GESC Engineer's Cost Estimate, for Initial/Interim and Final GESC stages, including anticipated maintenance during the construction phase, shall be submitted in the GESC Report. Units shall be consistent between cost estimate and plans. <u>Unit costs used to develop probable erosion and sediment control costs shall be those shown in the spreadsheet and shall not be modified.</u>
			E. GESC PLAN AND REPORT CHECKLIST
			A copy of this GESC Plan and Report Checklist must be completely filled out, signed by the designer, and submitted with the GESC Report.

Yes	No	N/A	GESC Requirements
-----	----	-----	-------------------

II. GESC PLANS (shall be a stand-alone document and not included in the Construction Drawings)

			A. GESC PLAN COVER SHEET
			1. Name of Project/Site Name
			2. Project Address
			3. Owner Contact Information (Name, Company, Address, Phone)
			4. Engineer Contact Information (Name, Company, Address, Phone)
			5. Plan Sheet Index
			6. Case Number(s) in the lower left-hand corner
			<p>7. The following note: <i>"This Grading, Erosion and Sediment Control (GESC) document has been placed in the project file for this project and appears to fulfill the latest version of the Grading, Erosion and Sediment Control Manual. Additional grading, erosion and sediment Control Measures may be required of the owner or his/her agents, due to unforeseen erosion problems or if the submitted plan does not function as intended. The requirements of this GESC document shall run with the land and be the obligation of the land owner, or his/her designated representative(s) until such time as the plan is properly completed, modified or voided."</i></p>
			<p>8. GESC Drawing Design Engineer's signature block with name, date, and Professional Engineer registration number. Signature block shall include the following certification statement: <i>"I hereby attest that this Grading, Erosion, and Sediment Control (GESC) document for (name of subdivision/development) has been prepared by me or under my direct supervision, and to the best of my knowledge and ability has been prepared in accordance with the latest version of the GESC Manual. The signature and stamp affixed hereon certifies that this GESC document was prepared in accordance with the required regulations and criteria; however, the stamp and signature does not certify or guarantee future performance of the execution of the plan by the Contractor. The Contractor is responsible for executing the construction work according to the information set forth in the plan and in accordance with all applicable requirements."</i> Registered Professional Engineer _____ State of Colorado No. _____ Affix Seal w/date</p>
			<p>9. Landowner/authorized agent acknowledging GESC review and the acceptance of GESC responsibility. Signature block shall include the following certification statement: <i>"I hereby certify that the Grading, Erosion, and Sediment Control Measures for (Name of Subdivision/Development) shall be constructed according to the design presented in this document. I understand that additional</i></p>

Yes	No	N/A	GESC Requirements
			<p>erosion control, sediment control and water quality enhancing measures may be required of the owner and his or her agents due to unforeseen pollutant discharges or if the submitted plan does not function as intended. The requirements of the plan shall be the obligation of the land owner and/or his successors or heirs; until such time as the plan is properly completed, modified or voided.”</p> <p>Owner or Authorized Agent _____ Authorized Signature _____ Date _____</p>
			10. Approval Block (see Appendix G) 4.5” x 5.5”
			11. General Location Map at a Scale of 1-inch to 1000-feet to 8000-feet indicating:
			a. General vicinity of the site location
			b. Major roadway names and drainageways
			c. North arrow and scale
			B. GESC DRAWING INDEX SHEET
			For projects that require multiple plan-view sheets to adequately show the project area (based on the specified scale ranges), a single plan-view sheet shall be provided at a scale appropriate to show the entire site on one sheet. Areas of coverage of the multiple blow-up sheets are to be indicated as rectangles on the index sheet.
			C. INITIAL GESC DRAWING
			This plan sheet shall provide grading, erosion and sediment Control Measures for the initial clearing, grubbing and preparation of a project. At a minimum, it shall contain:
			1. Property lines, adjacent roads and drainageways
			2. Existing and proposed easements
			3. Existing topography at 1- or 2-foot contour intervals, extending a minimum of 100 feet beyond the property line or the limits of construction if the project goes beyond property lines
			4. Labeled location of any existing structures or hydrologic features within the mapping boundary
			5. Flow arrows
			6. Labeled floodplain delineation including Control Measures to delineate and protect floodplain (e.g. construction fence, construction markers, wire-backed silt fence)
			7. North arrow and scale
			8. Approval Block (see Appendix G) 4.5” x 2”
			9. Limits of construction encompassing all areas of work access points, storage and staging areas, borrow areas, stockpiles, construction trailer, and utility tie-in location in on-site and off-site locations.
			10. Stream corridors and other resource areas to be preserved and all other areas outside the limits of construction shall be lightly shaded to clearly show area not to be disturbed

Yes	No	N/A	GESC Requirements
			11. Location of stockpiles, including topsoil, imported aggregates, and excess material
			12. Location of storage and staging areas for equipment, equipment maintenance, fuel, lubricant, chemical (and other materials) and waste storage
			13. Location of borrow or disposal areas
			14. Location of temporary roads, including haul roads
			15. Location, map symbol, and letter callouts of all initial erosion and sediment Control Measures
			16. Location, map symbol, and letter callouts of Vehicle Tracking Control(s) (VTC)
			17. Location, map symbol, and letter callouts of Concrete Washout Area(s) (CWA)
			18. Location, map symbol, and letter callouts of dedicated asphalt and concrete batch plants.
			19. Locations of other areas or operations where spills can occur – Refer to Chapter 10.
			20. Location, map symbol, and letter callouts for any anticipated Dewatering (DW) activities. Note: Dewatering of groundwater is covered by State permits. The Permittee is responsible for obtaining and complying with State-issued permits
			21. Information to be specified for each Control Measure, such as type and dimensions as called for in Chapter 11 of the GESC Manual.
			22. The following notes:
			a. Appropriate Control Measures must be implemented prior to the start of land disturbance activity, must control potential pollutants during each phase of construction, and must be continued through final stabilization. Appropriate structural and non-structural Control Measures must be maintained in operational condition.
			b. See Standard Notes and Details (Sheet 1) for legend of Control Measures names and symbols.
			c. Any Control Measures shown that require grading, (e.g. sediment basins, sediment traps, concrete washout areas, etc.), shall not be placed until after the pre-construction meeting and issuance of the GESC permit, but must be fully functional prior to any large-scale grading. The initial plan illustrates existing conditions. No proposed infrastructure is shown.
			D. INTERIM GESC DRAWING
This plan sheet shows Control Measures to control grading, erosion and sediment during the initial over lot grading, site construction and site re-vegetation process. The Interim GESC Plan shall show all the information included on the Initial GESC Plan, as noted below. At a minimum, it shall contain the following information:			

Yes	No	N/A	GESC Requirements
			1. Existing topography and location of all existing erosion and sediment Control Measures on site, as shown on the Initial GESC Plan shall be screened/shaded back.
			2. Dimension and quantity information for Initial stage Control Measures shall not be shown.
			3. Items from the Initial GESC Plan (except #20 and #21).
			4. Proposed topography at 1- or 2-foot contour intervals, showing elevations, dimensions, locations, and slope of all proposed grading with flow arrows.
			5. Outlines of cut and fill areas. Summary of cut and fill volumes. If export occurs, note location where export will likely be transported to. Separate cut/fill sheet is permissible.
			6. Location of all interim erosion and sediment Control Measures designed in conjunction with the proposed site topography and implementing the Control Measures installed in the Initial GESC Plan.
			7. Locations of all improvements, drainage features and facilities, and other permanent features to be constructed in connection with, or as a part of, the proposed work, per approved plat or land use plan.
			8. The following notes:
			a. Appropriate Control Measures must be implemented prior to the start of land disturbance activity, must control potential pollutants during each phase of construction, and must be continued through final stabilization. Appropriate structural and non-structural Control Measures must be maintained in operational condition.
			b. See Standard Notes and Details (Sheet 1) for legend of names and symbols.
			c. Screened/shaded back Control Measures were installed in the Initial stage and shall be left in place in the Interim stage unless otherwise noted.
			d. Control Measures, including seeding and mulching of disturbed areas, must be completed within 14 days, if the area will remain undisturbed for a period greater than 30 days.
			e. All proposed slopes on this plan have a maximum slope of 3:1. Any slopes between 3:1 and 4:1 will require the use of erosion control blankets or flexible growth medium, as approved by the GESC Inspector.
			f. See Construction Plans for details of permanent drainage facilities such as detention facilities, water quality facilities, culverts, storm drains, and inlet and outlet protection.
			g. If site runoff enters the post-construction permanent Control Measure(s), sediment contamination of the materials may result in the post-construction permanent Control Measures(s) having to be reconstructed in its entirety. (Where applicable) Removal of sediment basin on site shall only occur after <u>all</u> areas tributary to

Yes	No	N/A	GESC Requirements
			the sediment basin have been stabilized. Removal must be approved by the GESC Inspector.
			E. FINAL GESC DRAWING
This plan sheet shows controls for final completion of the site. The Final GESC Plan shall include all information shown on the Initial and Interim Plans, as noted below. At a minimum, this plan sheet shall contain the following information:			
			1. Existing topography in areas of proposed contours need not be shown.
			2. Existing Initial and Interim Control Measures shall be shown, (screened/shaded back) . Dimension and quantity information shall not be shown for Initial and Interim Control Measures except for Control Measures to remain during final stabilization.
			3. Directional flow arrows on all drainage features.
			4. Items from the Interim GESC Plan (except #5 and #8).
			5. Label all Initial or Interim Control Measures (e.g. SSA, VTC, DW, etc.) that are to be removed and any resulting disturbed areas to be stabilized.
			6. Location of all Final erosion and sediment Control Measures (including seeding and mulching of any areas not stabilized in the Interim Plan), permanent landscaping, and any Control Measures necessary to minimize the movement of sediment off site until permanent vegetation can be established.
			7. Show and label areas of sod and permanent landscaping classifications per approved land use plan.
			8. The following notes:
			a. Appropriate Control Measures must be implemented prior to the start of land disturbance activity, must control potential pollutants during each phase of construction, and must be continued through final stabilization. Appropriate structural and non-structural Control Measures must be maintained in operational condition.
			b. See Standard Notes and Details (Sheet 1) for legend of names and symbols.
			c. Screened/shaded back Control Measures were installed in the Initial or Interim stage and, unless otherwise indicated, shall be left in place until approved by the GESC Inspector.
			d. All Interim Control Measures, including seeding and mulching or disturbed areas, must be completed within 14 days if the areas will remain undisturbed for a period greater than 30 days.
			e. All proposed slopes on this plan have a maximum slope of 3:1. Any slopes between 3:1 and 4:1 will require the use of erosion control blankets or flexible growth medium, as approved by the GESC Inspector
			f. See Construction Plans for details of permanent drainage facilities such as detention facilities, water quality facilities, culverts, storm drains, and inlet and outlet protection.

Yes	No	N/A	GESC Requirements
			g. Acceptance of the post-construction permanent Control Measures will not occur until all tributary areas to the permanent Control Measures are final stabilized.

			F. GESC PLAN - STANDARD NOTES AND DETAILS
--	--	--	--

A copy of the GESC Plan - Standard Notes and Details (included in Appendix F) shall be bound into each set of GESC Plans.

Signature of Design Engineer

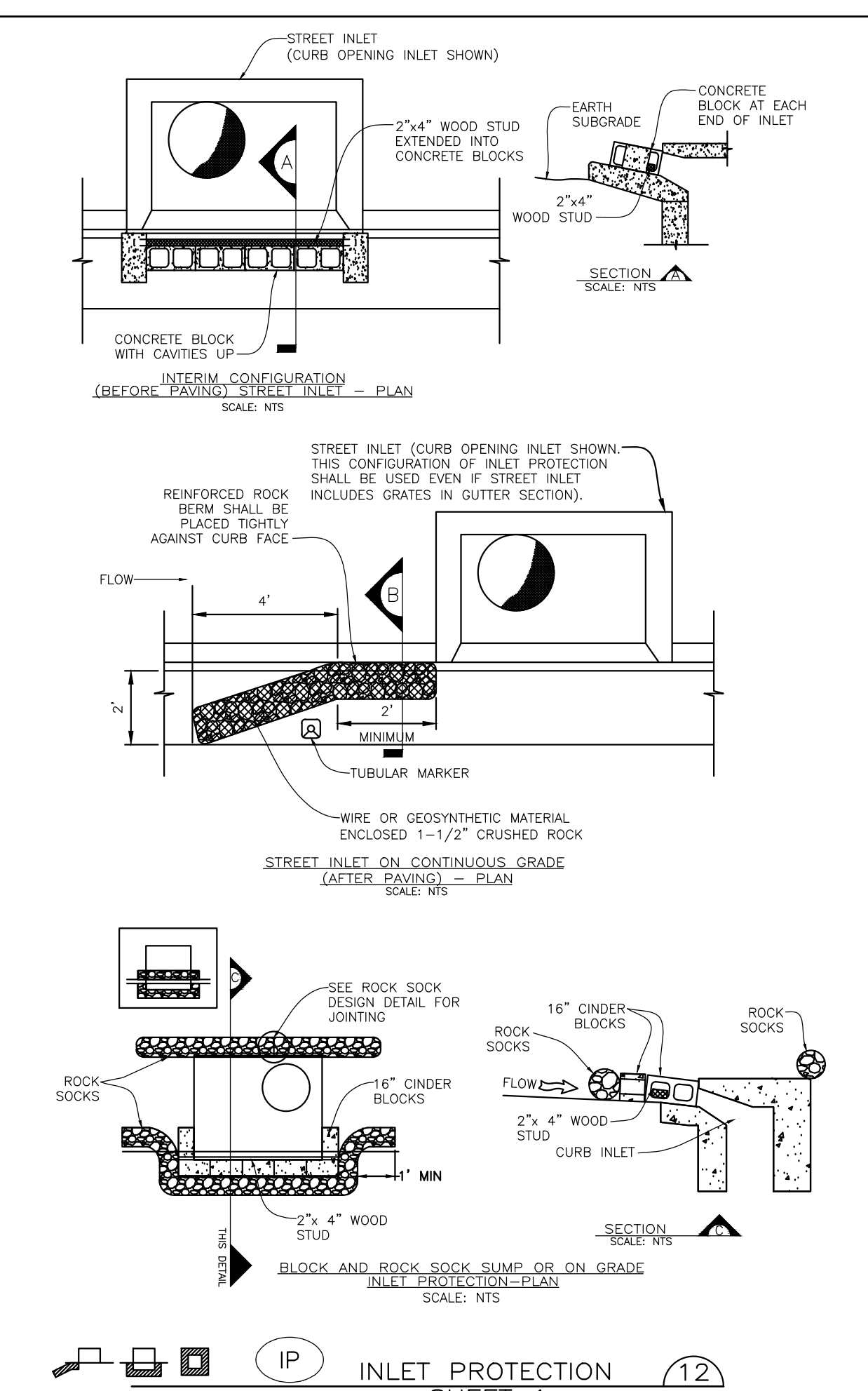
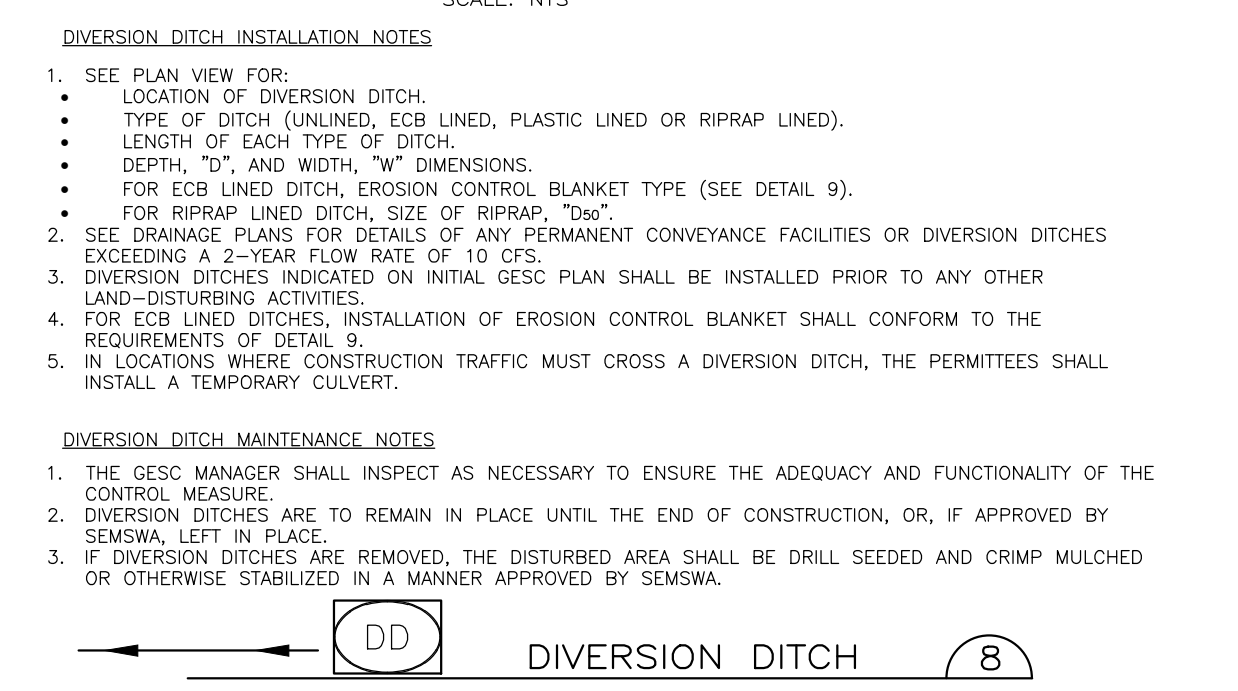
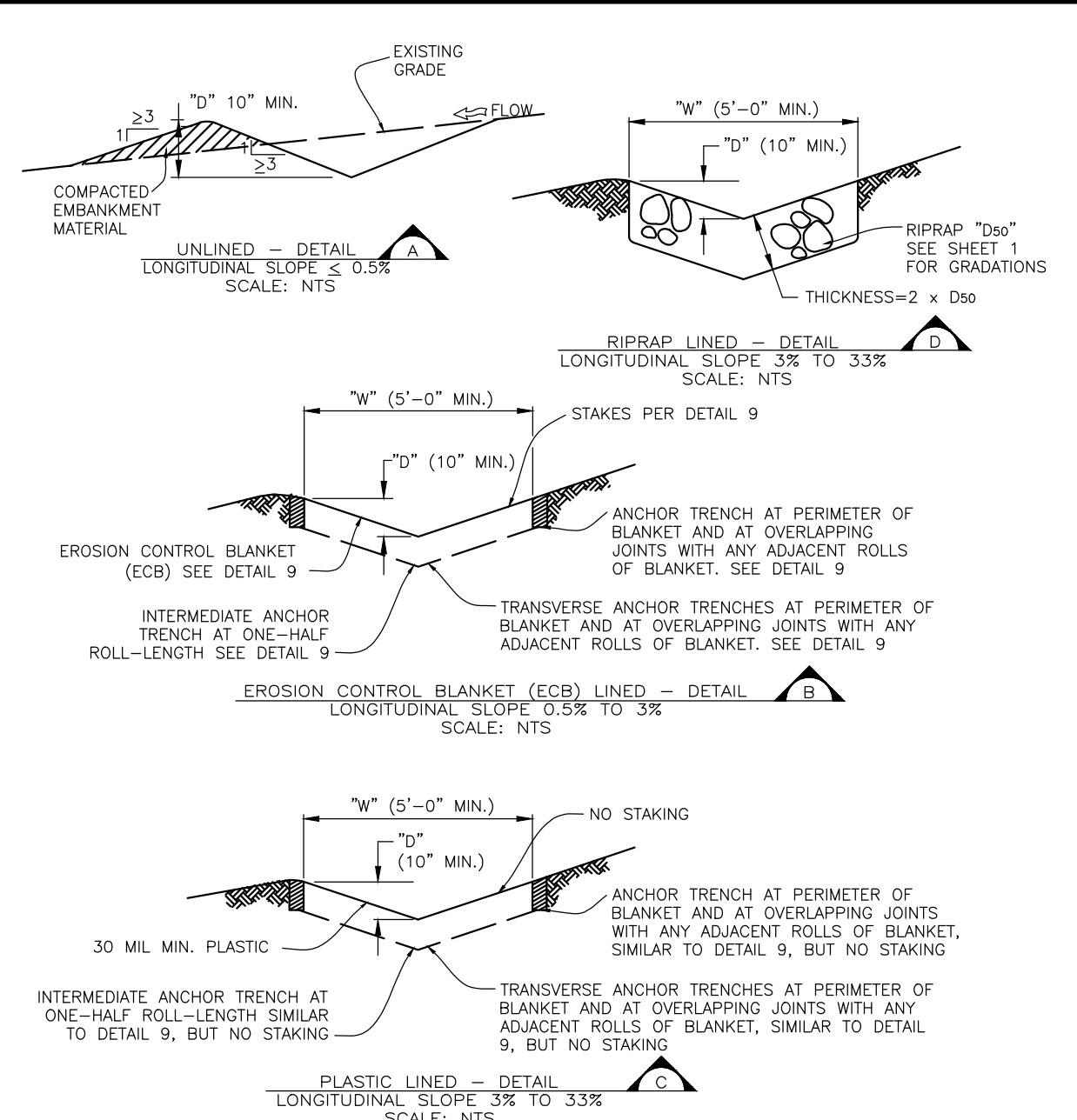

UTILITY NOTIFICATION CENTER OF COLORADO
CALL BEFORE YOU DIG
811
 Call 2 days prior to any digging, grading or excavating for the marking of underground member utilities

SOUTHEAST METRO STORMWATER AUTHORITY
 7437 SOUTH FAIRPLAY STREET
 CENTENNIAL COLORADO
 80112-4486
 (303) 858-8844 - INSPECTION DIVISION

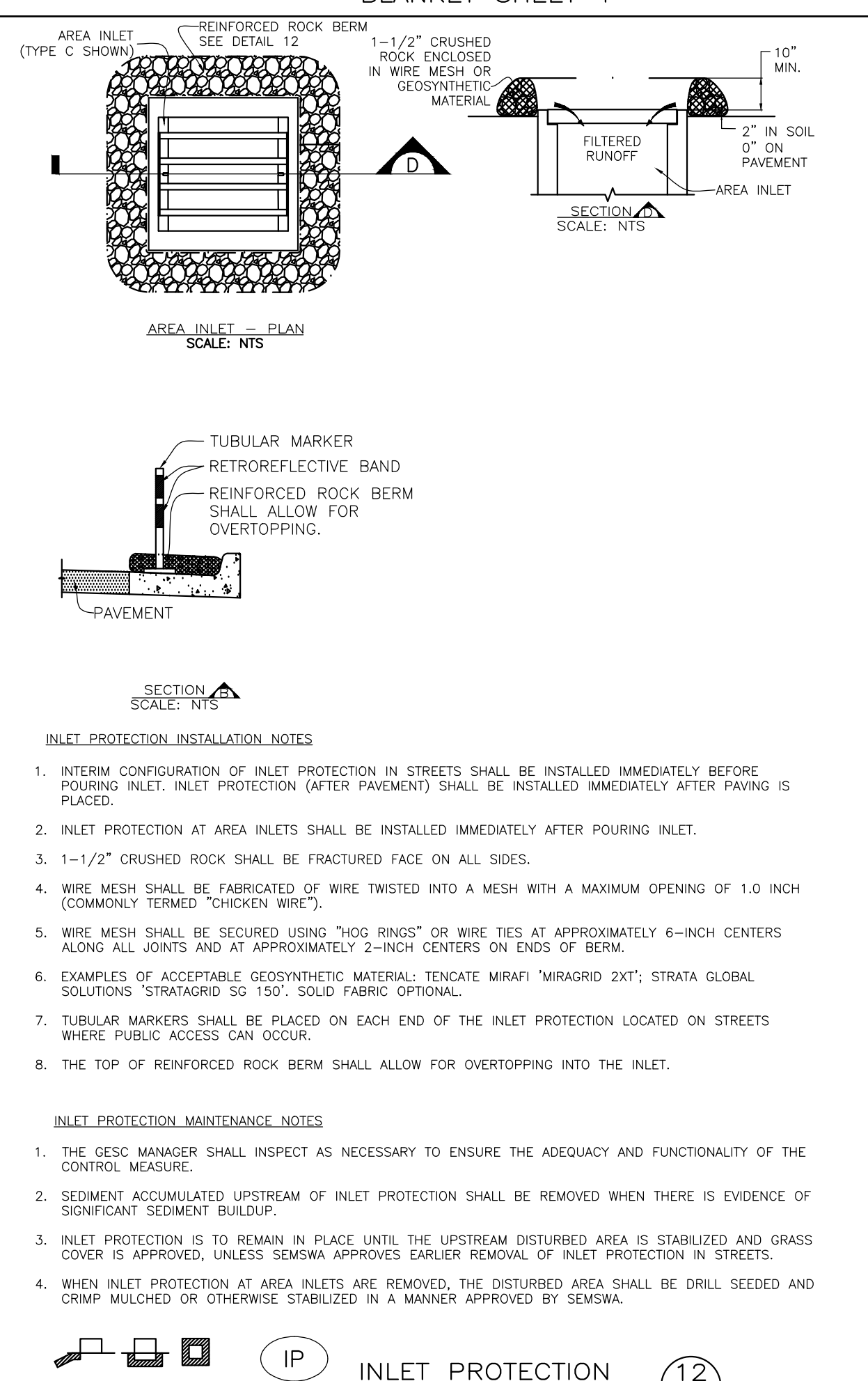
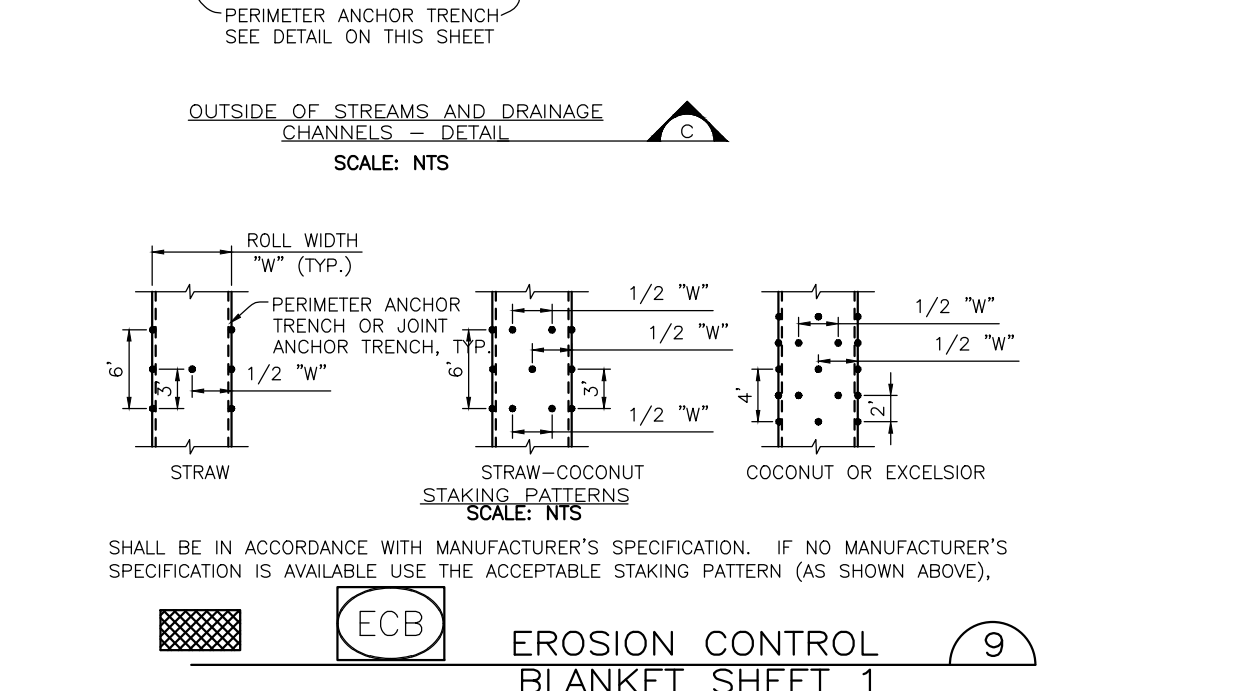
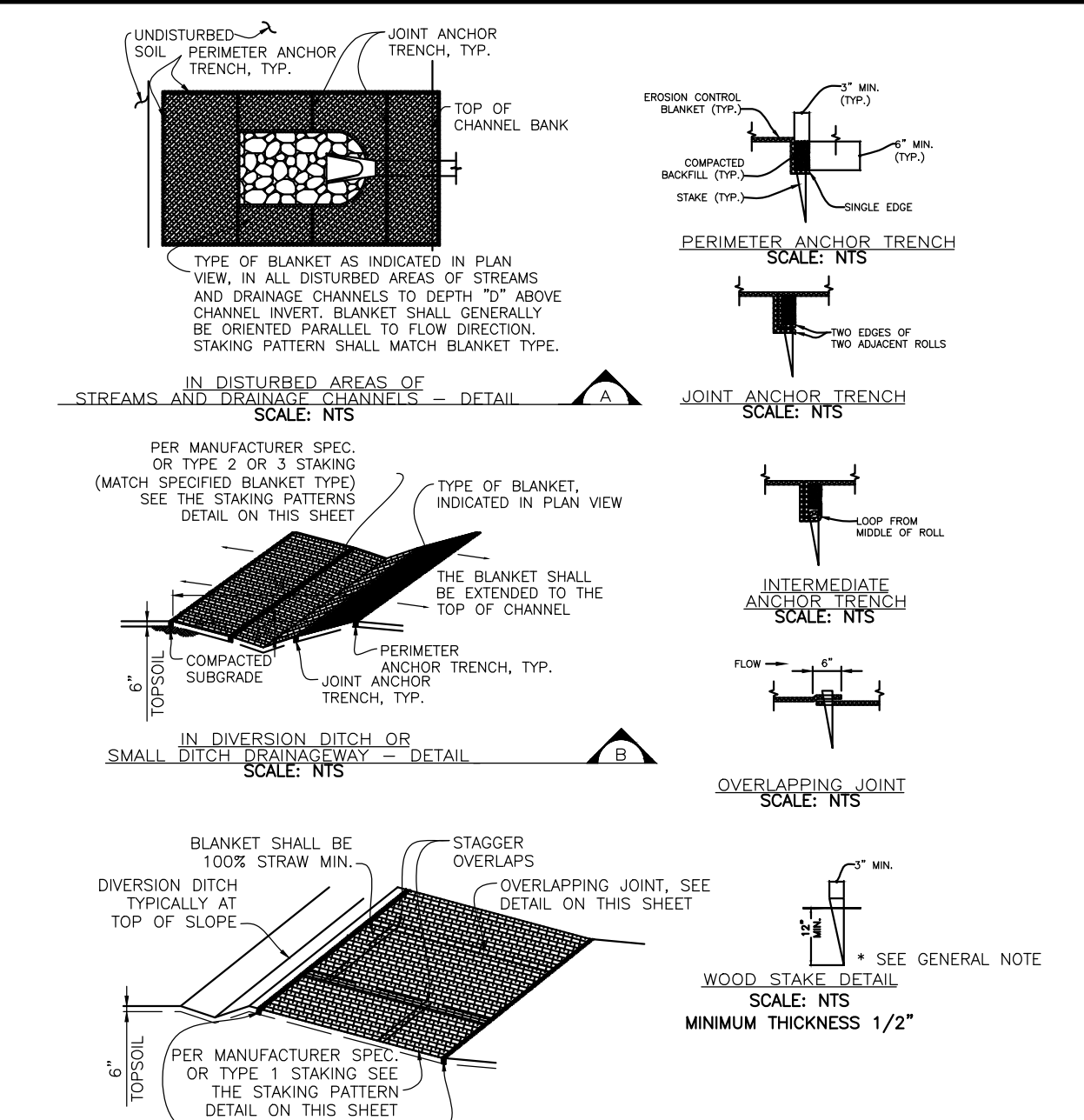

UTILITY NOTIFICATION CENTER OF COLORADO
CALL BEFORE YOU DIG
811
 Call 2 days prior to any digging, grading or excavating for the marking of underground member utilities

SOUTHEAST METRO STORMWATER AUTHORITY
 7437 SOUTH FAIRPLAY STREET
 CENTENNIAL COLORADO
 80112-4486
 (303) 858-8844 - INSPECTION DIVISION

- EROSION CONTROL BLANKET INSTALLATION NOTES**
- SEE PLAN VIEW FOR:
 - LOCATION OF PERIMETER OF EROSION CONTROL BLANKET.
 - TYPE OF BLANKET (STRAW, STRAW-COCOONUT, COCONUT, OR EXCELSIOR).
 - AREA "A" IN SQUARE YARDS OF EACH TYPE OF BLANKET.
 - ALL EROSION CONTROL BLANKETS, STAKES, AND NETTING SHALL BE MADE OF 100% NATURAL AND BIODEGRADABLE MATERIAL; NO PLASTIC OR OTHER SYNTHETIC MATERIAL, INCLUDING PHOTO-DEGRADABLE, SHALL BE ALLOWED.
 - IN AREAS WHERE EROSION CONTROL BLANKET IS SHOWN ON THE PLANS, THE PERMITTEE SHALL PLACE TOPSOIL AND PERFORM FINAL GRADING, SURFACE PREPARATION, AND SEEDING BELOW THE BLANKET IN ACCORDANCE WITH THE REQUIREMENTS OF DETAIL 19. SEEDING AND MULCHING, SUBGRADE SHALL BE SMOOTH AND MOST PRIOR TO BLANKET INSTALLATION AND THE BLANKET SHALL BE IN FULL CONTACT WITH SUBGRADE. NO GAPS OR VOIDS SHALL EXIST UNDER THE BLANKET.
 - PERIMETER ANCHOR TRENCH SHALL BE USED AT OUTSIDE PERIMETER OF ALL BLANKET AREAS. FOLLOW ALL MANUFACTURER'S INSTALLATION SPECIFICATIONS.
 - INTERMEDIATE ANCHOR TRENCH SHALL BE USED AT SPACING OF ONE-HALF THE ROLL LENGTH FOR COCONUT AND EXCELSIOR BLANKETS.
 - MATERIAL SPECIFICATIONS OF EROSION CONTROL BLANKET SHALL CONFORM TO TABLE 7.1.
 - ANY AREAS OF SEEDING AND MULCHING DISTURBED IN THE PROCESS OF INSTALLING EROSION CONTROL BLANKET SHALL BE RESEDED AND MULCHED IN ACCORDANCE WITH DETAIL 19.
 - SEE DRAINAGE DESIGN PLANS FOR MAJOR DRAINAGEWAY STABILIZATION MEASURES THAT MAY EXCEED THE DESIGN CONDITIONS ASSOCIATED WITH THE DETAILS ABOVE.

TABLE 7.1 - EROSION CONTROL BLANKET TYPE

TYPE	COCONUT CONTENT	STRAW CONTENT	EXCELSIOR CONTENT	NETTING MIN.
STRAW*	—	100%	—	—
STRAW-COCOONUT	30% MIN.	70% MAX.	—	DOUBLE/NATURAL
COCONUT	100%	—	—	DOUBLE/NATURAL
EXCELSIOR	—	—	100%	DOUBLE/NATURAL

* FOR OUTSIDE OF STREAMS AND DRAINAGE CHANNELS

- EROSION CONTROL BLANKET MAINTENANCE NOTES**
- THE GESC MANAGER SHALL INSPECT AS NECESSARY TO ENSURE THE ADEQUACY AND FUNCTIONALITY OF THE CONTROL MEASURE.
 - EROSION CONTROL BLANKET IS TO BE LEFT IN PLACE UNLESS REQUESTED TO BE REMOVED BY SEMSWA.
 - ANY EROSION CONTROL BLANKET PULLED OUT, TORN, OR OTHERWISE DAMAGED SHALL BE RE-INSTALLED. ANY SUBGRADE AREAS BELOW THE BLANKET THAT HAVE ERODED TO CREATE A VOID UNDER THE BLANKET, OR THAT REMAIN DEVOID OF GRASS SHALL BE REPAIRED, RESEDED AND MULCHED AND THE EROSION CONTROL BLANKET REINSTALLED.
 - REMOVAL OF 2X4 WEDGE STAKES MAY BE REQUIRED PRIOR TO FINAL CLOSE OUT OF THE GESC PERMIT.
- GENERAL NOTE:**
 ECO-STAKES MAY BE USED IN AREAS ABOVE ORDINARY HIGH WATER MARK.

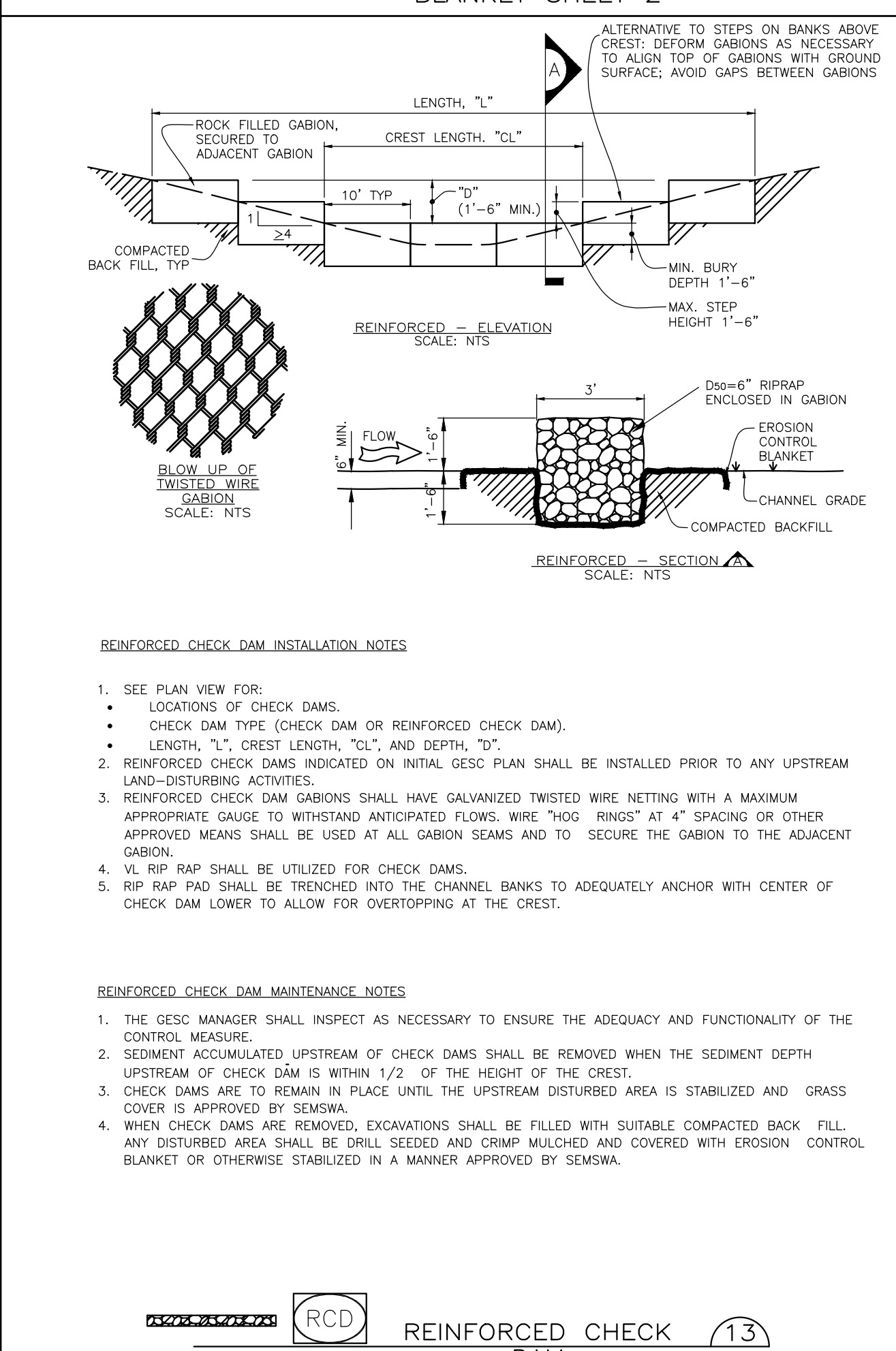

UTILITY NOTIFICATION CENTER OF COLORADO
CALL BEFORE YOU DIG
811
 Call 2 days prior to any digging, grading or excavating for the marking of underground member utilities

SOUTHEAST METRO STORMWATER AUTHORITY
 7437 SOUTH FAIRPLAY STREET
 CENTENNIAL COLORADO
 80112-4486
 (303) 858-8844 - INSPECTION DIVISION

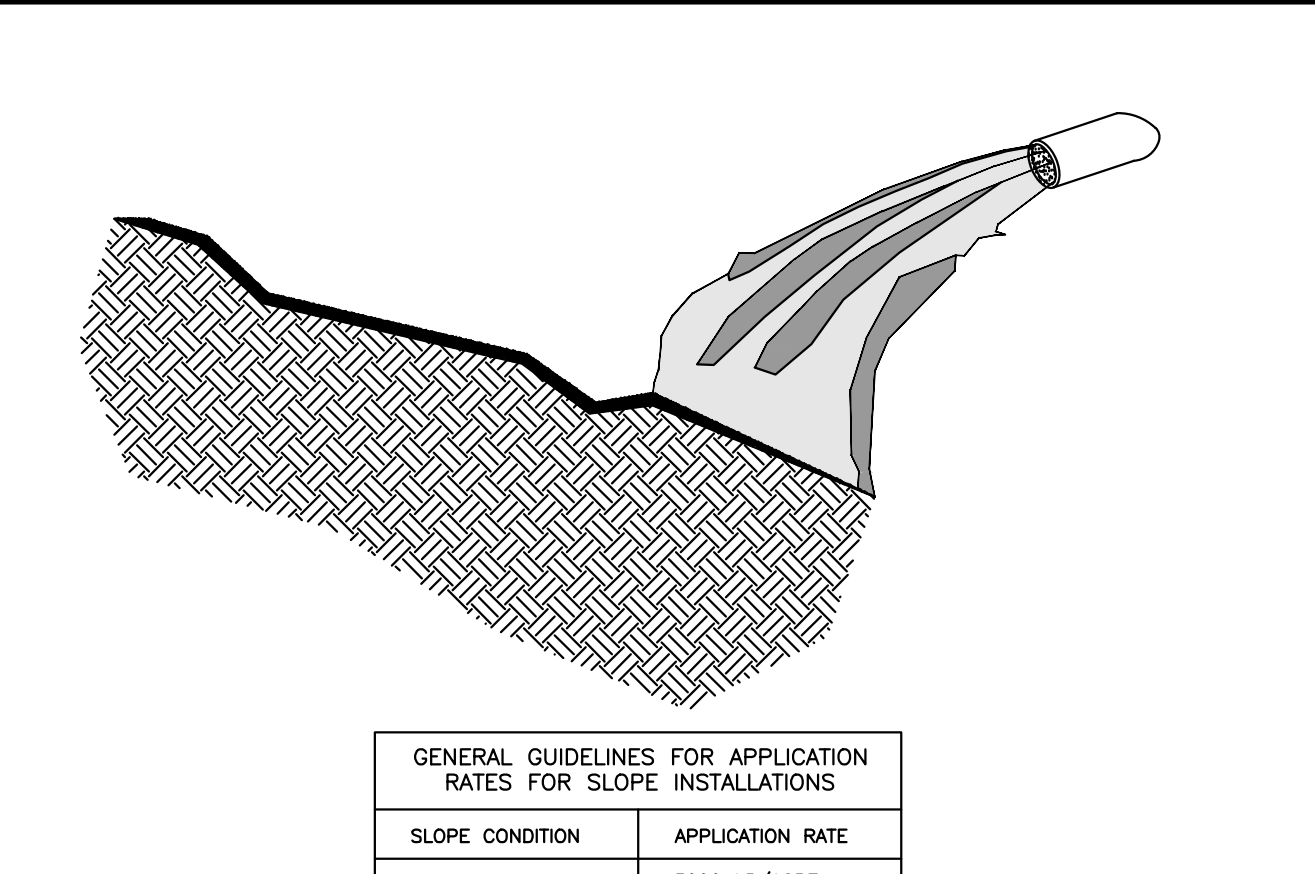

- GENERAL GUIDELINES FOR APPLICATION RATES FOR SLOPE INSTALLATIONS**
- | SLOPE CONDITION | APPLICATION RATE |
|-----------------|------------------|
| ≤3H:1V | 3000 LB/ACRE |
- FLEXIBLE GROWTH MEDIUM INSTALLATION NOTES:**
- IN AREAS WHERE THE FLEXIBLE GROWTH MEDIUM IS SHOWN ON THE PLANS, THE PERMITTEE(S) SHALL PLACE TOPSOIL AND PERFORM FINAL GRADING, SURFACE PREPARATION, AND SEEDING BELOW THE BLANKET IN ACCORDANCE WITH THE GESC PLAN STANDARD NOTES AND DETAILS, SEEDING AND MULCHING. APPLY THE FLEXIBLE GROWTH MEDIUM TO GEOTECHNICALLY STABLE SLOPES THAT HAVE BEEN DESIGNED AND CONSTRUCTED TO DIVERT RUNOFF AWAY FROM THE FACE OF THE SLOPE. DO NOT PROCEED WITH INSTALLATION UNTIL SATISFACTORY CONDITIONS ARE ESTABLISHED.
 - HYDROSEEDING IS NOT ALLOWED. PLEASE FOLLOW SEED AND MULCH DETAIL (DETAIL 19).
 - MIX AND APPLY PER MANUFACTURER'S DETAILS. FRESHLY SEEDED SURFACES AND DO NOT LEAVE SEEDED SURFACES UNPROTECTED. CONFIRM LOADING RATES WITH EQUIPMENT MANUFACTURER.
 - APPLY FGM FROM OPPOSITE DIRECTIONS TO ASSURE 100% SOIL SURFACE COVERAGE. SLOPE DEVICES OR WATER DIVERSION TECHNIQUES ARE RECOMMENDED WHEN SLOPE LENGTHS EXCEED 75 FT.
 - ANY AREAS OF SEEDING AND MULCHING DISTURBED IN THE PROCESS OF INSTALLING FGM SHALL BE RESEDED AND MULCHED IN ACCORDANCE WITH DETAIL 19.
- NOTE:**
 THE FLEXIBLE GROWTH MEDIUM SHOULD NOT BE APPLIED IN CHANNELS, SWALES OR OTHER AREAS WHERE CONCENTRATED FLOWS ARE ANTICIPATED, UNLESS INSTALLED IN CONJUNCTION WITH A TEMPORARY EROSION CONTROL BLANKET.

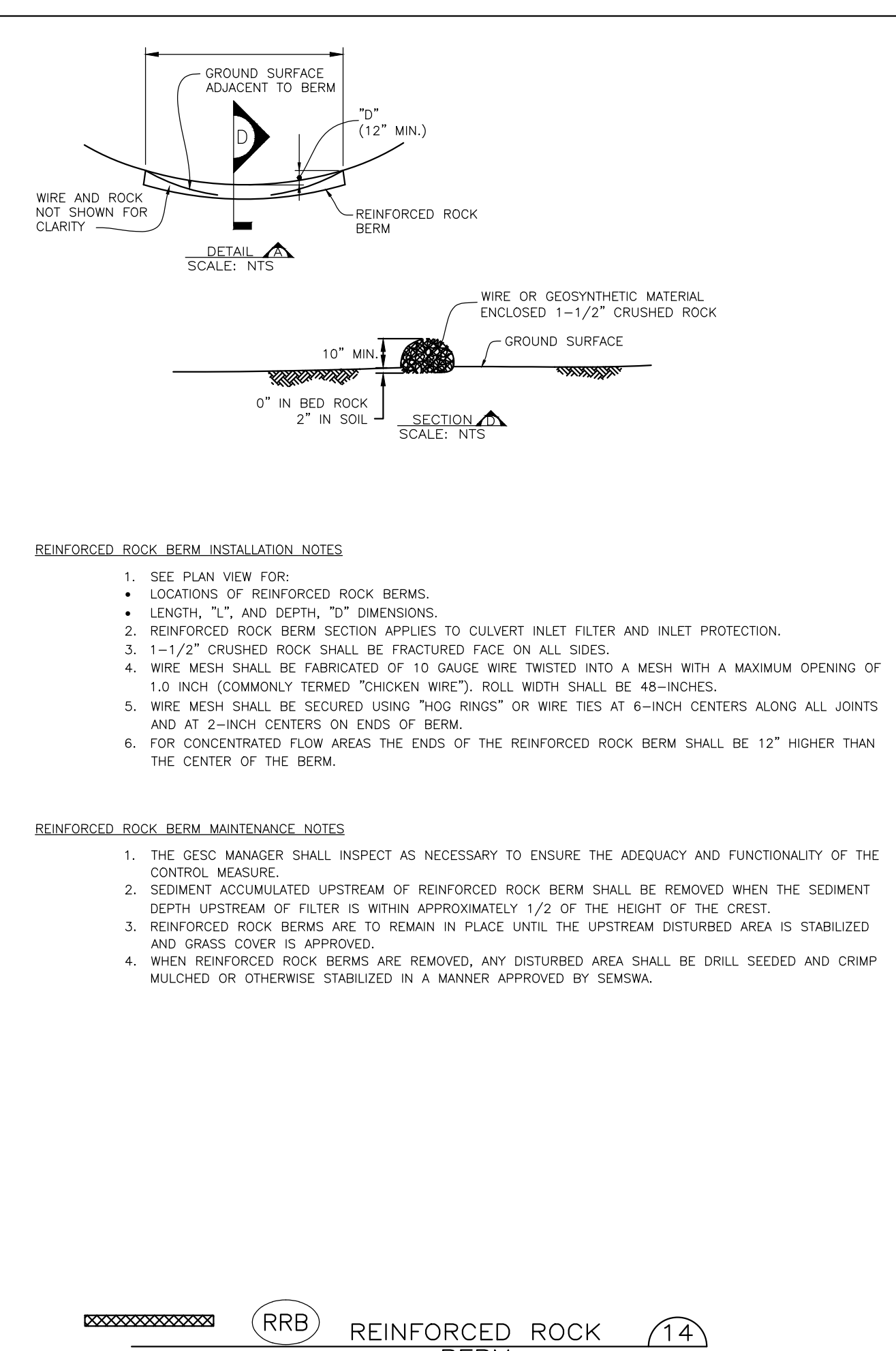

UTILITY NOTIFICATION CENTER OF COLORADO
CALL BEFORE YOU DIG
811
 Call 2 days prior to any digging, grading or excavating for the marking of underground member utilities

SOUTHEAST METRO STORMWATER AUTHORITY
 7437 SOUTH FAIRPLAY STREET
 CENTENNIAL COLORADO
 80112-4486
 (303) 858-8844 - INSPECTION DIVISION

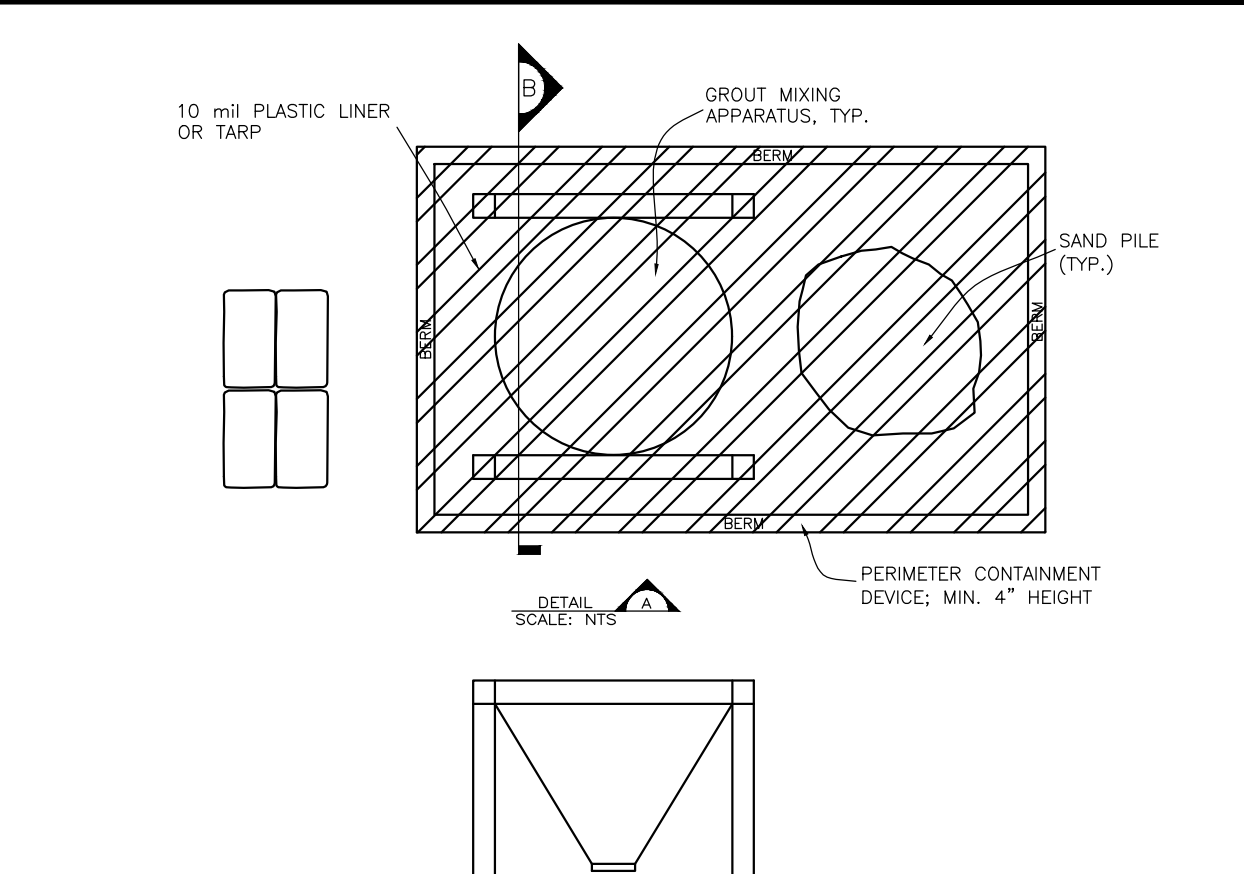

- GROUT MIXING STATION INSTALLATION NOTES**
- LOCATION TO BE DETERMINED IN THE FIELD AND SHALL BE SITUATED A MINIMUM OF 50' FROM STORM DRAIN INLETS, OPEN DRAINAGE FACILITIES AND WATER COURSES.
 - AREA TO BE LARGE ENOUGH TO PROVIDE ADEQUATE CONTAINMENT OFF ALL MIXING OPERATIONS.
 - MIXING AREA TO HAVE PERIMETER CONTAINMENT, A MINIMUM OF 4" IN HEIGHT. CONTAINMENT DEVICE CAN BE CONSTRUCTED OF AN EARTHEN BERM, CONCRETE BLOCKS, WOOD FRAME SECURELY FASTENED AROUND PERIMETER AREA OR OTHER APPROVED METHOD. MUST BE SIZED TO ADEQUATELY CONTAIN MIXING OPERATION.
 - EXCAVATED MATERIAL MAY BE USED IN PERIMETER BERM CONSTRUCTION.
 - MINIMUM 10 MIL PLASTIC LINER OR TARP SHALL COVER THE ENTIRE MIXING AREA SECURELY FASTENED TO THE RAISED CONTAINMENT DEVICE.
- GROUT MIXING STATION MAINTENANCE NOTES**
- THE GESC MANAGER SHALL INSPECT AS NECESSARY TO ENSURE THE ADEQUACY AND FUNCTIONALITY OF THE CONTROL MEASURE.
 - ALL GROUT / MORTAR WASHOUT SHALL BE IN AN APPROVED CONCRETE WASHOUT AREA (CWA).
 - ALL MATERIALS SHALL BE STORED AND COVERED ON PALLETS ADJACENT TO THE MIXING AREA.
 - LINER AND ALL GROUT / MORTAR WASTE RESIDUE SHALL BE PROPERLY DISPOSED OF AT THE END OF THE MIXING OPERATION.

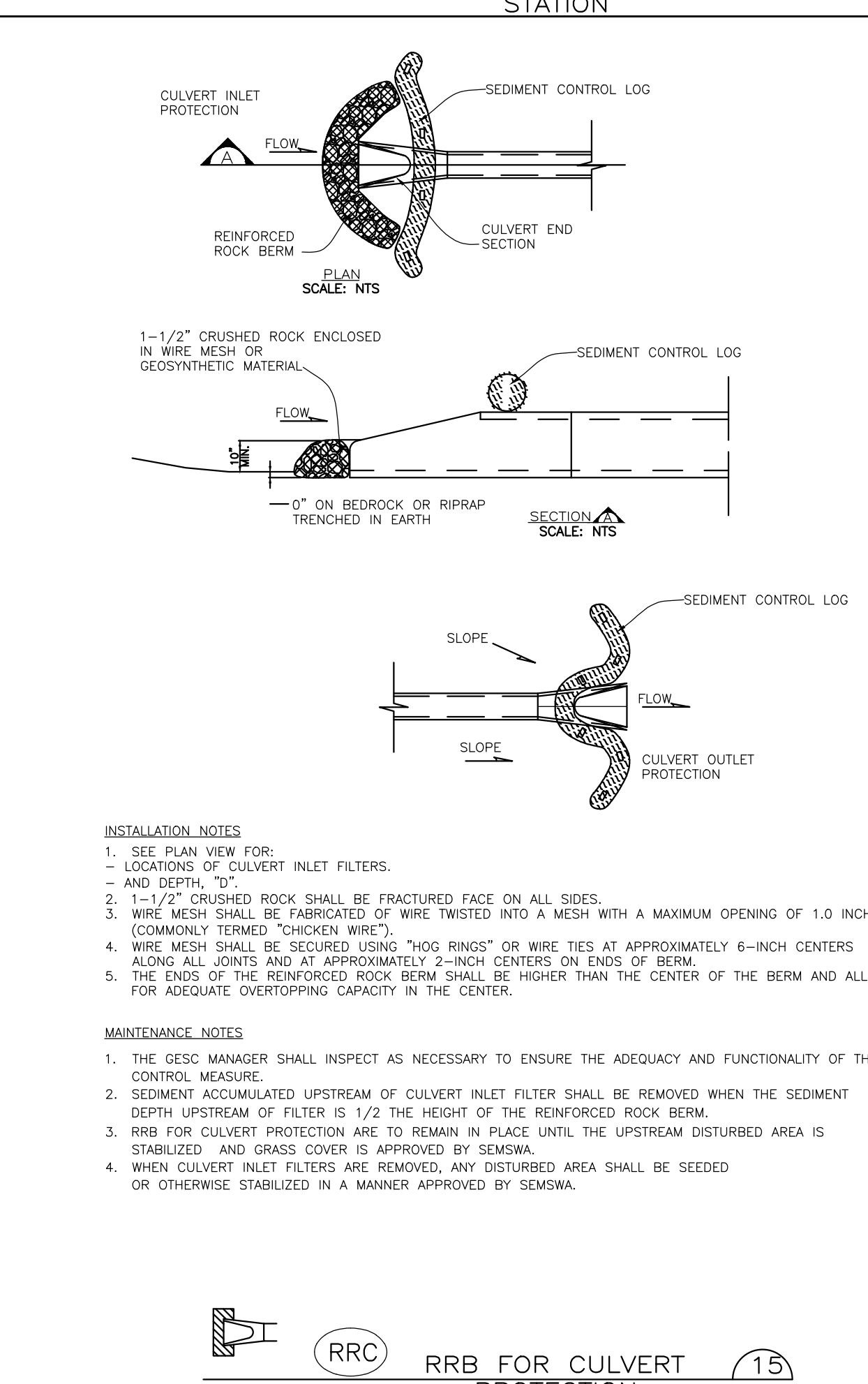

UTILITY NOTIFICATION CENTER OF COLORADO
CALL BEFORE YOU DIG
811
 Call 2 days prior to any digging, grading or excavating for the marking of underground member utilities

SOUTHEAST METRO STORMWATER AUTHORITY
 7437 SOUTH FAIRPLAY STREET
 CENTENNIAL COLORADO
 80112-4486
 (303) 858-8844 - INSPECTION DIVISION

GRADING EROSION AND SEDIMENT CONTROL
STANDARD NOTES AND DETAILS
REVISED FEBRUARY 2023

GESC SHEET 2 OF 4

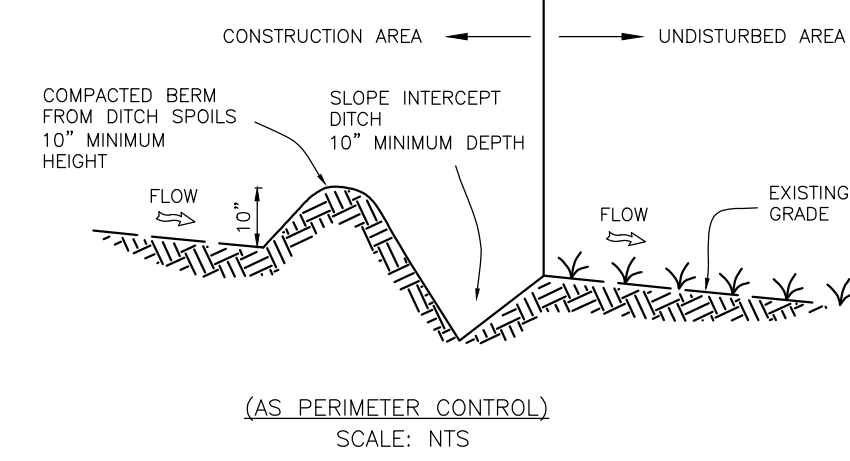
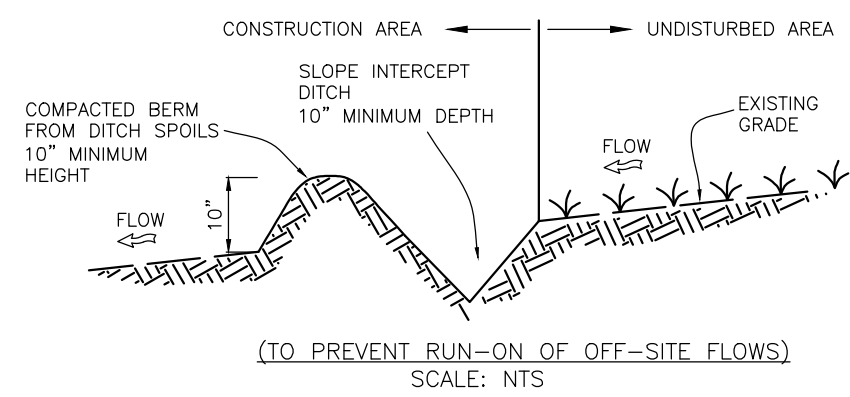

- SLOPE INTERCEPT DITCH INSTALLATION NOTES**
1. MATERIALS CUT OUT OF DITCH TO FORM A COMPACTED BERM ADJACENT TO AND ON THE CONSTRUCTION AREA SIDE OF DITCH.
 2. SLOPE INTERCEPT DITCH SHALL HAVE A MINIMUM DEPTH OF 10".
 3. COMPACTED BERM SHALL HAVE A MINIMUM HEIGHT OF 10".
 4. SLOPE INTERCEPT DITCH SHALL BE CUT IN ON THE CONTOUR.
 5. SLOPE INTERCEPT DITCH CAN BE USED IN PLACE OF SILT FENCE (SF) AND SEDIMENT CONTROL LOGS (SCL).
 6. SEE PLAN VIEW FOR LOCATION.

- SLOPE INTERCEPT DITCH MAINTENANCE NOTES**
1. THE GESC MANAGER SHALL INSPECT AS NECESSARY TO ENSURE THE ADEQUACY AND FUNCTIONALITY OF THE CONTROL MEASURE.
 2. SEDIMENT ACCUMULATED IN DITCH SHALL BE REMOVED WHEN DITCH BECOMES 1/2 FULL. REMOVED SEDIMENT SHALL BE PLACED ON AND COMPACTED WITH THE ADJACENT BERM.
 3. BERM MATERIAL TO FILL DITCH UPON COMPLETION OF CONSTRUCTION. ALL DISTURBED AREAS TO BE SEEDED AND MULCHED PER DETAIL 19.

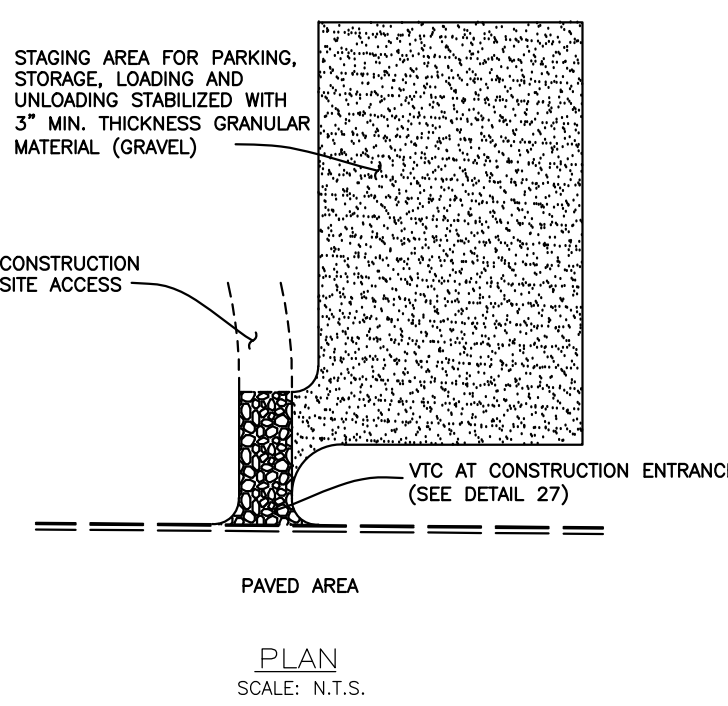

- STABILIZED STAGING AREA INSTALLATION NOTES**
1. SEE PLAN VIEW FOR GENERAL LOCATION OF STAGING AREA. CONTRACTOR MAY MODIFY LOCATION AND SIZE OF STABILIZED STAGING AREA WITH SEMSWA APPROVAL.
 2. STABILIZED STAGING AREA SHALL BE LARGE ENOUGH TO FULLY CONTAIN PARKING, STORAGE, AND UNLOADING AND LOADING OPERATIONS.
 3. IF REQUIRED BY SEMSWA, SITE ACCESS ROADS SHALL BE STABILIZED IN THE SAME MANNER AS THE STAGING AREA.
 4. STAGING AREA SHALL BE STABILIZED PRIOR TO ANY OTHER OPERATIONS ON THE SITE.
 5. THE STABILIZED STAGING AREA SHALL CONSIST OF A MINIMUM OF 3" OF GRANULAR MATERIAL (GRAVEL).

- STABILIZED STAGING AREA MAINTENANCE NOTES**
1. THE GESC MANAGER SHALL INSPECT AS NECESSARY TO ENSURE THE ADEQUACY AND FUNCTIONALITY OF THE CONTROL MEASURE.
 2. GESC MANAGER SHALL PROVIDE ADDITIONAL THICKNESS OF GRANULAR MATERIAL IF ANY RUTTING OCCURS OR UNDERLYING SUBGRADE BECOMES EXPOSED.
 3. STABILIZED STAGING AREA SHALL BE ENLARGED IF NECESSARY TO CONTAIN PARKING, STORAGE, AND UNLOADING AND LOADING OPERATIONS.
 4. ANY ACCUMULATED DIRT OR MUD SHALL BE REMOVED FROM THE SURFACE OF THE STABILIZED STAGING AREA.
 5. THE STABILIZED STAGING AREA SHALL BE REMOVED AT THE END OF CONSTRUCTION. THE GRANULAR MATERIAL SHALL BE REMOVED OR, IF APPROVED BY SEMSWA, USED ON SITE, AND THE AREA TOPSOILED, DRILL SEEDED AND CRIMP MULCHED OR OTHERWISE STABILIZED.

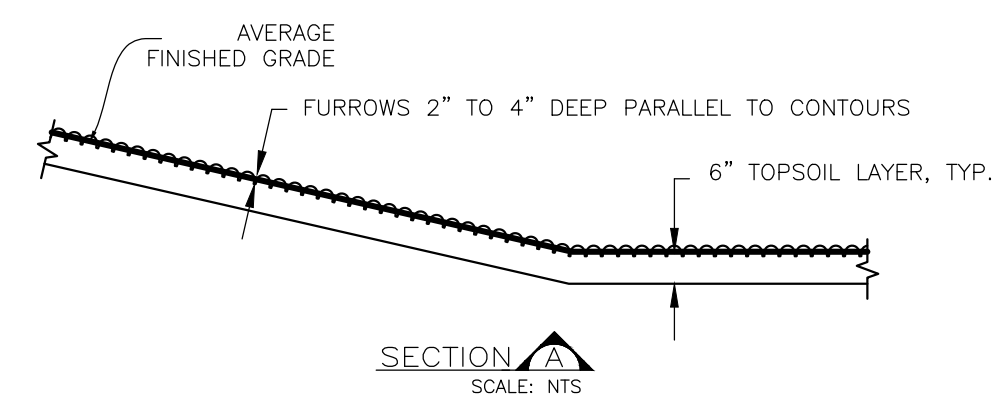

- SURFACE ROUGHENING INSTALLATION NOTES**
1. SURFACE ROUGHENING SHALL BE PROVIDED ON ALL FINISHED GRADES (SLOPES AND "FLAT" AREAS) WITHIN 2 DAYS OF COMPLETION OF FINISHED GRADE (FOR AREAS NOT RECEIVING TOPSOIL) OR WITHIN 2 DAYS OF TOPSOIL PLACEMENT.
 2. AREAS WHERE BUILDING FOUNDATIONS, PAVEMENT, OR SOD IS TO BE PLACED WITHIN 7-DAYS OF FINISHED GRADING DO NOT NEED TO BE SURFACE ROUGHENED.
 3. DISTURBED SURFACES SHALL BE ROUGHENED USING RIPPING OR TILLING EQUIPMENT ON THE CONTOUR OR TRACKING UP AND DOWN A SLOPE USING EQUIPMENT TREADS.

- SURFACE ROUGHENING MAINTENANCE NOTES**
1. THE GESC MANAGER SHALL INSPECT AS NECESSARY TO ENSURE THE ADEQUACY AND FUNCTIONALITY OF THE CONTROL MEASURE.
 2. VEHICLES AND EQUIPMENT SHALL GENERALLY BE CONFINED TO ACCESS DRIVES AND SHALL NOT BE DRIVEN OVER AREAS THAT HAVE BEEN SURFACE ROUGHENED.
 3. IN NON-TURF GRASS FINISHED AREAS, SEEDING AND MULCHING SHALL TAKE PLACE DIRECTLY OVER SURFACE ROUGHENED AREAS WITHOUT FIRST SMOOTHING OUT THE SURFACE.
 4. IN AREAS NOT SEEDED AND MULCHED AFTER SURFACE ROUGHENING, SURFACES SHALL BE RE-ROUGHENED AS NECESSARY TO MAINTAIN GROOVE DEPTH AND SMOOTH OVER ANY RILL EROSION.

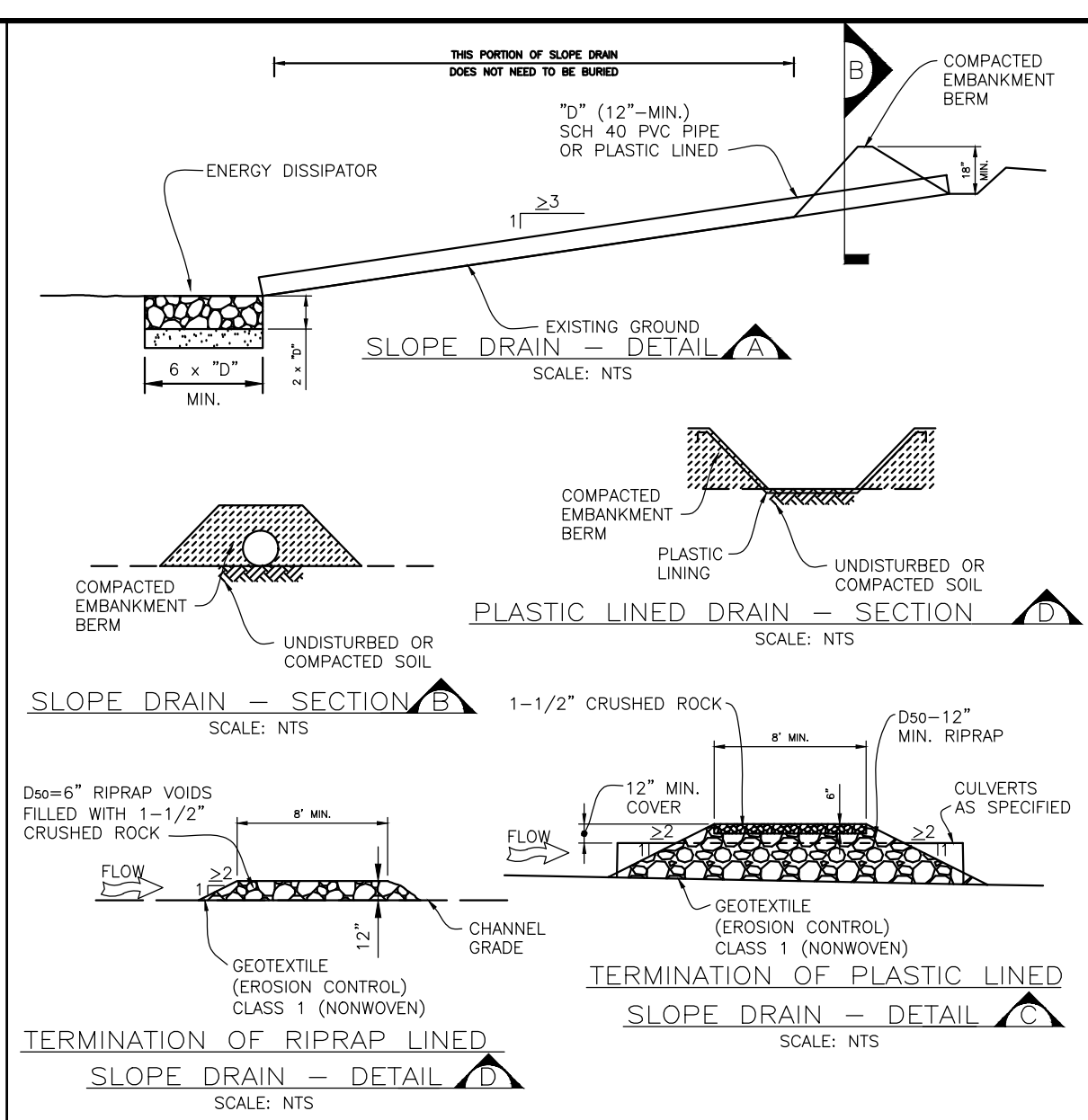

- SLOPE DRAIN INSTALLATION NOTES**
1. SEE PLAN VIEW FOR:
 - LOCATION AND LENGTH OF SLOPE DRAIN.
 - PIPE DIAMETER, "D", AND RIPRAP SIZE, "D₅₀".
 2. SLOPE DRAIN DIMENSIONS SHALL BE CONSIDERED MINIMUM DIMENSIONS; CONTRACTOR MAY ELECT TO INSTALL LARGER FACILITIES. ANY DAMAGE TO SLOPE OR SLOPE DRAIN DURING RUNOFF EVENTS SHALL BE THE CONTRACTOR'S RESPONSIBILITY.
 3. SLOPE DRAINS INDICATED ON INITIAL GESC PLAN SHALL BE INSTALLED PRIOR TO ANY UPSTREAM LAND-DISTURBING ACTIVITIES.
 4. FOR TEMPORARY SLOPE DRAINS, PIPE MAY BE INSTALLED ON TOP OF SLOPE; HOWEVER, 12" MIN. COVER AT TOP OF SLOPE SHALL BE PROVIDED.
 5. AN ENERGY DISSIPATOR SHALL BE PLACED AT THE OUTFALL OF THE SLOPE DRAIN.

- SLOPE DRAIN MAINTENANCE NOTES**
1. THE GESC MANAGER SHALL INSPECT AS NECESSARY TO ENSURE THE ADEQUACY AND FUNCTIONALITY OF THE CONTROL MEASURE.
 2. TEMPORARY SLOPE DRAINS ARE TO REMAIN IN PLACE UNTIL NO LONGER NEEDED, BUT SHALL BE REMOVED PRIOR TO THE END OF CONSTRUCTION. WHEN SLOPE DRAINS ARE REMOVED, THE DISTURBED AREA SHALL BE DRILL SEEDED AND CRIMP MULCHED OR OTHERWISE STABILIZED IN A MANNER APPROVED BY SEMSWA.

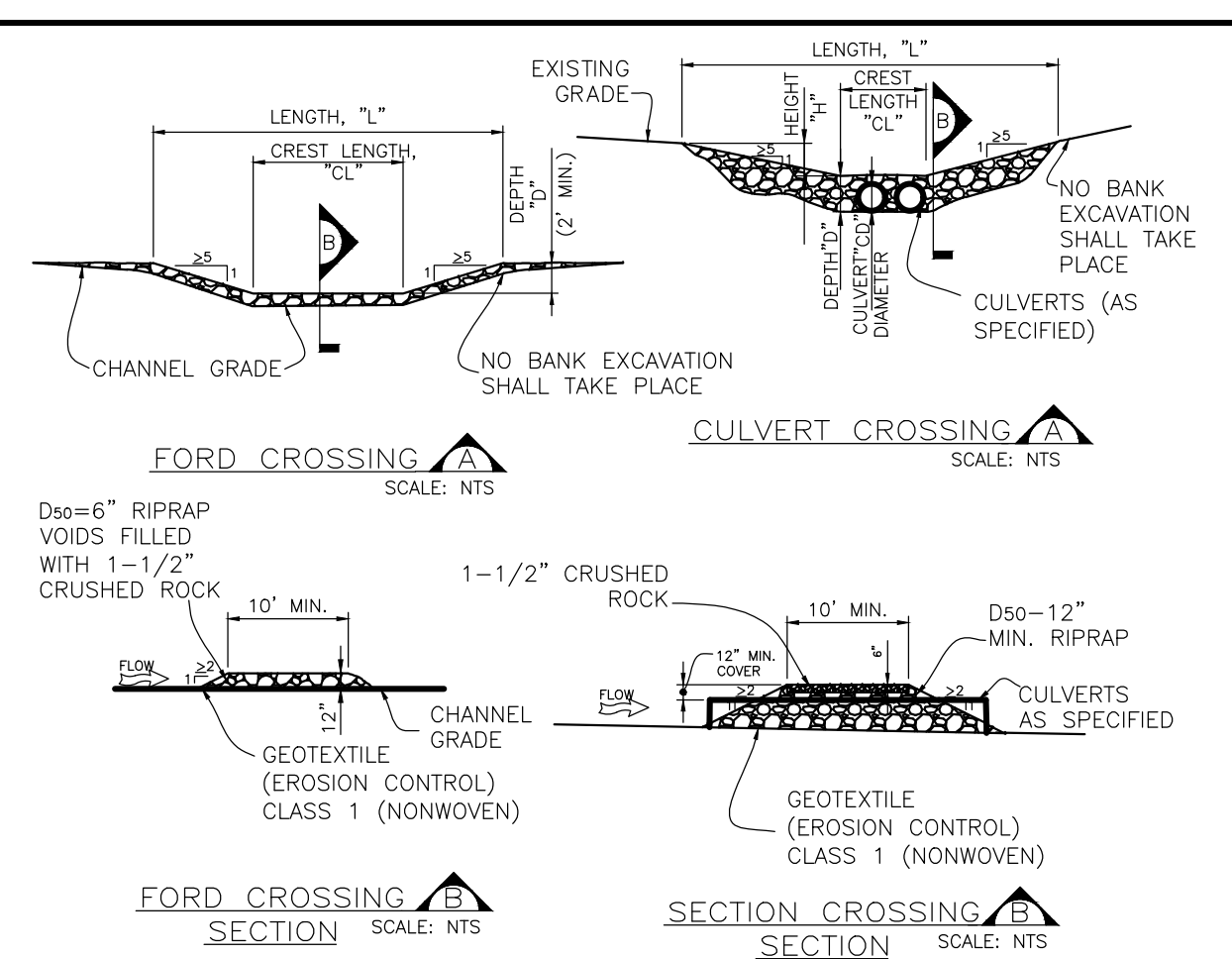

- TEMPORARY STREAM CROSSING INSTALLATION NOTES**
1. SEE PLAN VIEW FOR:
 - LOCATIONS OF TEMPORARY STREAM CROSSING.
 - LENGTH, "L", CREST LENGTH, "CL", CROSSING HEIGHT, "H", DEPTH, "D", CULVERT DIAMETER, "CD", AND NUMBER, TYPE AND CLASS OR GAUGE OF CULVERTS.
 2. TEMPORARY STREAM CROSSING DIMENSIONS, D₅₀, AND NUMBER OF CULVERTS INDICATED (FOR CULVERT CROSSINGS) SHALL BE CONSIDERED MINIMUM DIMENSIONS. ENGINEER MAY ELECT TO INSTALL LARGER FACILITIES. ANY DAMAGE TO STREAM CROSSING OR EXISTING STREAM CHANNEL DURING BASEFLOW OR FLOOD EVENTS SHALL BE THE CONTRACTOR'S RESPONSIBILITY.
 3. SEE SHEET 1 FOR RIPRAP AND 1-1/2" CRUSHED ROCK GRADATIONS.
 4. FOR A TEMPORARY STREAM CROSSING THAT WILL CARRY LOADS, THE TEMPORARY STREAM CROSSING MUST BE DESIGNED BY THE DESIGN ENGINEER, AND ONLY USED IF APPROVED BY SEMSWA.

- TEMPORARY STREAM CROSSING MAINTENANCE NOTES**
1. THE GESC MANAGER SHALL INSPECT AS NECESSARY TO ENSURE THE ADEQUACY AND FUNCTIONALITY OF THE CONTROL MEASURE.
 2. SEDIMENT ACCUMULATED UPSTREAM OF STREAM CROSSINGS SHALL BE REMOVED WHEN THE SEDIMENT DEPTH UPSTREAM OF CROSSING IS WITHIN 50% OF THE CREST (FORD CROSSING) OR GREATER THAN AN AVERAGE DEPTH OF 50% (CULVERT CROSSING).
 3. STREAM CROSSINGS ARE TO REMAIN IN PLACE UNTIL NO LONGER NEEDED, BUT SHALL BE REMOVED PRIOR TO THE END OF CONSTRUCTION.
 4. WHEN STREAM CROSSINGS ARE REMOVED, THE DISTURBED AREA SHALL BE DRILL SEEDED AND CRIMP MULCHED AND COVERED WITH EROSION CONTROL BLANKET OR OTHERWISE STABILIZED IN A MANNER APPROVED BY SEMSWA.

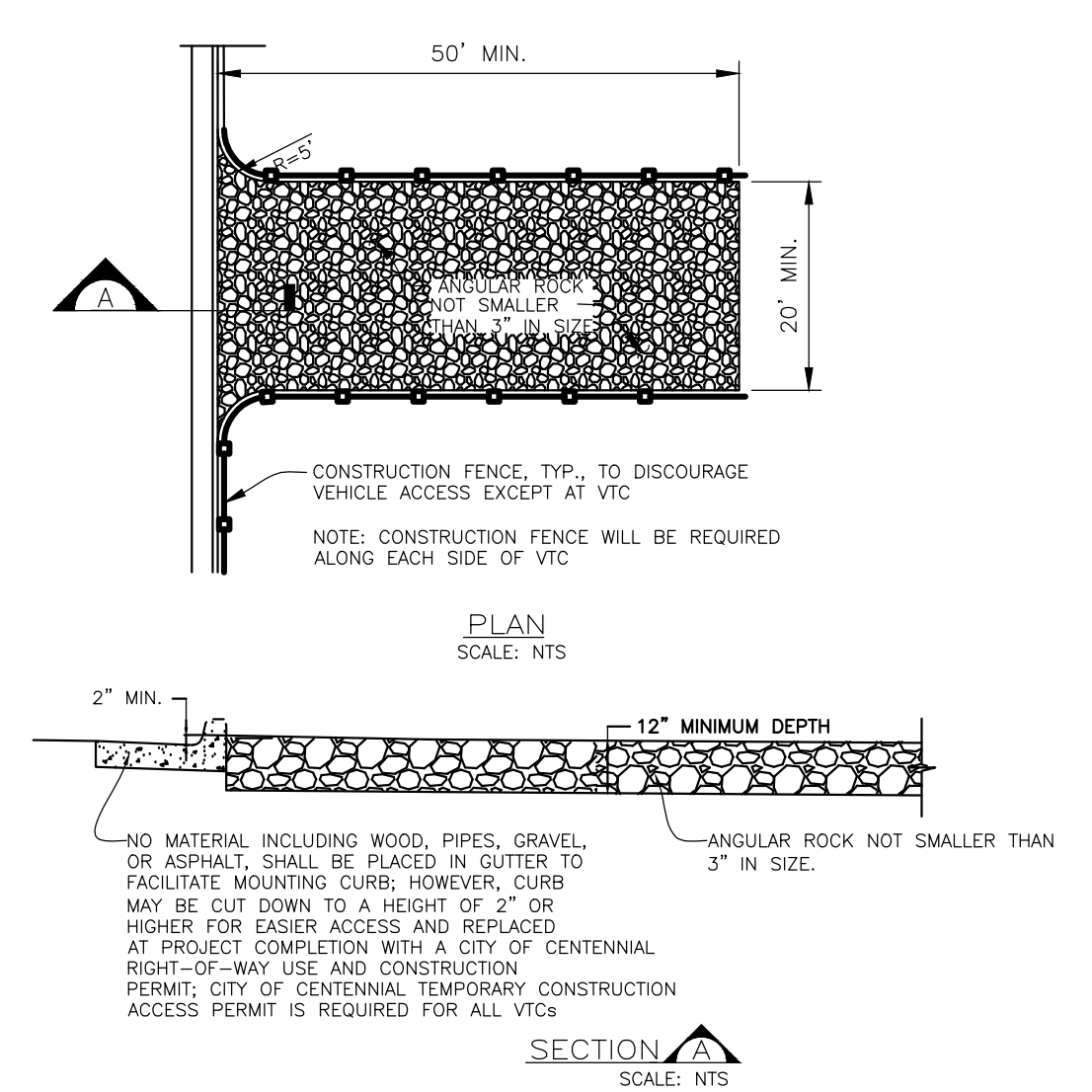

- VEHICLE TRACKING CONTROL INSTALLATION NOTES**
1. VEHICLE TRACKING CONTROL PADS SHALL BE INSTALLED AT EVERY EXIT POINT OF THE SITE.
 2. VEHICLE TRACKING CONTROL PADS SHALL CONSIST OF HARD, DENSE, DURABLE STONE, ANGULAR IN SHAPE AND RESISTANT TO WEATHERING. ROUNDED STONE OR BOULDERS WILL NOT BE ACCEPTABLE. THE STONES SHALL NOT BE SMALLER THAN 3" IN SIZE. THE STONE SHALL HAVE A SPECIFIC GRAVITY OF AT LEAST 2.6. CONTROL OF GRADATION WILL BE BY VISUAL INSPECTIONS.
 3. ANY CRACKED OR DAMAGED CURB AND GUTTER AND SIDEWALK SHALL BE REPLACED BY PERMITTEE.

- VEHICLE TRACKING CONTROL MAINTENANCE NOTES**
1. THE GESC MANAGER SHALL INSPECT AS NECESSARY TO ENSURE THE ADEQUACY AND FUNCTIONALITY OF THE CONTROL MEASURE.
 2. VEHICLE TRACKING CONTROL SHALL BE REMOVED AT THE END OF CONSTRUCTION. THE ROCK MATERIAL REMOVED OR, IF APPROVED BY SEMSWA, USED ON SITE, AND THE AREA TOPSOILED, DRILL SEEDED AND CRIMP MULCHED OR OTHERWISE STABILIZED.

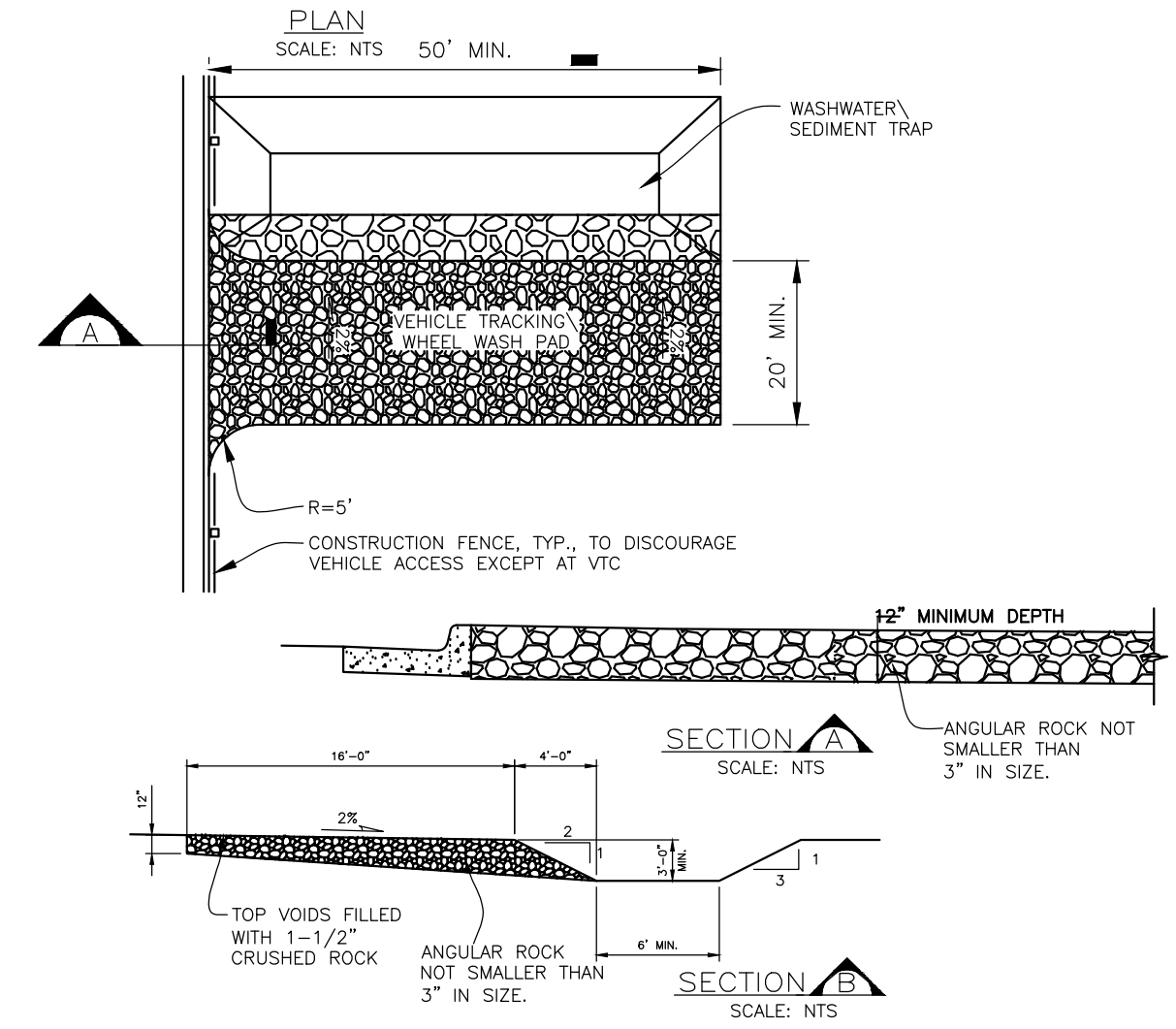

- VEHICLE TRACKING CONTROL WITH WHEEL WASH INSTALLATION NOTES**
1. SEMSWA RESERVES THE RIGHT TO REQUIRE VEHICLE TRACKING CONTROL WITH WHEEL WASH FACILITIES AT SITES WHERE TRACKING ONTO PAVED AREAS BECOMES A SIGNIFICANT PROBLEM.
 2. IF VEHICLE TRACKING CONTROL WITH WHEEL WASH FACILITIES ARE REQUIRED, ALL WHEELS ON EVERY VEHICLE LEAVING THE SITE SHALL BE CLEANED OF MUD USING A PRESSURE-WASHER. THE CONTRACTOR SHALL BE RESPONSIBLE FOR OBTAINING A WATER SOURCE.
 3. VEHICLE TRACKING CONTROL PADS SHALL CONSIST OF HARD, DENSE, DURABLE STONE, ANGULAR IN SHAPE AND RESISTANT TO WEATHERING. ROUNDED STONE OR BOULDERS WILL NOT BE ACCEPTABLE. THE STONES SHALL NOT BE SMALLER THAN 3" IN SIZE. THE STONE SHALL HAVE A SPECIFIC GRAVITY OF AT LEAST 2.6. CONTROL OF GRADATION WILL BE BY VISUAL INSPECTIONS.
 4. ANY CRACKED OR DAMAGED CURB AND GUTTER AND SIDEWALK SHALL BE REPLACED BY CONTRACTOR.

- VEHICLE TRACKING CONTROL WITH WHEEL WASH MAINTENANCE NOTES**
1. THE GESC MANAGER SHALL INSPECT AS NECESSARY TO ENSURE THE ADEQUACY AND FUNCTIONALITY OF THE CONTROL MEASURE.
 2. ACCUMULATED SEDIMENT IN THE WASHWATER/SEDIMENT TRAP SHALL BE REMOVED WHEN THE SEDIMENT DEPTH REACHES AN AVERAGE OF 12-INCHES.
 3. VEHICLE TRACKING CONTROL WITH WHEEL WASH FACILITY SHALL BE REMOVED AT THE END OF CONSTRUCTION. THE RIPRAP MATERIAL REMOVED OR, IF APPROVED BY THE COUNTY, USED ON SITE, AND THE AREA TOPSOILED, DRILL SEEDED AND CRIMP MULCHED OR OTHERWISE STABILIZED.



UTILITY NOTIFICATION CENTER OF COLORADO
CALL BEFORE YOU DIG
811
Call 2 days prior to any digging, grading or excavating for the marking of underground member utilities



























SOUTHEAST METRO STORMWATER AUTHORITY
7437 SOUTH FAIRPLAY STREET
CENTENNIAL COLORADO
80112-4486
(303) 858-8844 - INSPECTION DIVISION

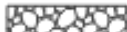

**GRADING EROSION AND SEDIMENT CONTROL
STANDARD NOTES AND DETAILS
REVISED FEBRUARY 2023**

**GESC
SHEET
4 OF 4**

Appendix G: Control Measure Legend and Approval Block

DETAIL NO.	SHEET NO.		LEGEND	
1	①		CBC	CUT BACK CURB
2	①		CD	CHECK DAM
3	①		CWA	CONCRETE WASHOUT AREA
4	①		CF	CONSTRUCTION FENCE
5	①		CM	CONSTRUCTION MARKERS
6	①		CS	CURB SOCK
7	①		DW	DEWATERING
8	②		DD	DIVERSION DITCH
9	②		ECB	EROSION CONTROL BLANKET
10	②		GMS	GROUT MIXING STATION
11	②		IP	INLET PROTECTION
12	②		RCD	REINFORCED CHECK DAM
13	②		RRB	REINFORCED ROCK BERM
14	②		RRC	RRB FOR CULVERT PROTECTION
15	②		SB	SEDIMENT BASIN
16	③		SCL	SEDIMENT CONTROL LOG
17	③		ST	SEDIMENT TRAP
18	③		SM	SEEDING AND MULCHING
19	③		SF	SILT FENCE
20	③		SID	SLOPE INTERCEPT DITCH
21	③		SSA	STABILIZED STAGING AREA
22	④		SR	SURFACE ROUGHENING
23	④		TSD	TEMPORARY SLOPE DRAIN
24	④		TSC	TEMPORARY STREAM CROSSING
25	④		VTC	VEHICLE TRACKING CONTROL
26	④		WW	VTC WITH WHEEL WASH
			LOC	ROCK AND RIPRAP GRADATIONS LIMITS OF CONSTRUCTION
			*EG	MAY MEET MAJOR MODIFICATION REQUIREMENTS

Appendix G: Control Measure Legend and Approval Block

SEMSWA ACCEPTANCE BLOCK

Engineering & Construction Division

**These plans have been reviewed by SEMSWA for Grading, Erosion,
and Sediment Control Improvements Only.**

Dimensions shall be 4.5" by 5.5"

Appendix H: Definitions

Abatement: A form of enforcement where SEMSWA may step in and take necessary action to mitigate non-compliance issues. The GESC Permit Holder must incur the costs of these actions.

Authorized Agent: Individual or agency responsible for maintaining compliance with the GESC permit requirements.

Burden of Proof: The obligation resting on a party to provide sufficient evidence for their position.

Check Dam (CD): Small rock dam designed to withstand overtopping, that is placed in a small stream or drainage way. The purpose of the check dam is to trap sediment-laden water in the backwater zone upstream of the check and to reduce flow velocities in a channel.

Collateral: All standard GESC Permittees and some Low Impact Permittees are required to post collateral in the form of Irrevocable Letter of Credit from a Colorado Bank or a National Bank with a Colorado Branch, or Cash Escrow in the form of a check. If the Collateral is in the form of a Letter of Credit, then the expiration date must be for a minimum of two years. The amount of collateral is based on the cost estimate of installing and maintaining the grading, erosions, and sediment controls required on a site.

Compensatory Action: Failure to comply with GESC requirements may result in temporary actions to mitigate the violation(s).

Concrete/Grout Washout Area (CWA, GWA): Shallow excavation with a small perimeter berm to isolate concrete truck washout operations.

Construction Activities: Refers to ground surface disturbing and associated activities (land disturbance), which include, but are not limited to, clearing, grading, excavation, demolition, installation of new or improved haul roads and access roads, staging areas, stockpiling of fill materials, and borrow areas. Construction does not include routine maintenance to maintain the original line and grade, hydraulic capacity, or original purpose of the facility. Activities to conduct repairs that are not part of regular maintenance or for replacement are construction activities and are not routine maintenance. Construction activity is from initial groundbreaking to final stabilization regardless of ownership of the construction activities.

Construction Fence (CF)/ Construction Markers (CM): Consists of orange plastic fencing, or other approved material, attached to support posts and used to control access to the construction site and delineate limits of construction.

Control Measure: Refers in the GESC Manual to a measure implemented by a contractor to control construction site erosion, sediment and waste. *Previously referred to as a Best Management Practice (BMP).

Control Regulation 72: The Cherry Creek Reservoir Control Regulation (5 CCR 1002-72). **Dewatering (DW):** Consists of a gravel filter provided on the suction end of a pump to reduce the pumping of sediment and a rip rap pad at the discharge end of the pump to provide erosion protection. Dewatering includes settling the discharge water in a small basin or sediment pond before releasing to receiving waters.

Dewatering Permit: CDPS Permit issued by the Water Quality Control Division for the discharge of construction dewatering source water to waters of the state. Construction dewatering source water means groundwater, surface water, and stormwater that have mixed with the groundwater and/ or surface water (i.e. commingled stormwater runoff) that has come into contact with Construction Activities.

Diversion Ditch (DD): Small earth channel used to divert and convey runoff to a sediment basin, check dam, or drainage way.

Engineering Cost Estimate (ECE): Applicants are required to provide an estimate associated with implementing the GESC Permit documents. The ECE provides unit cost information that is used to generate the cost estimate. The ECE is used to quantify the collateral required for a project.

Erosion Control Blanket (ECB): Fibrous blanket of straw, excelsior, or coconut material trenched in and staked down over prepared, seeded soil. The matting reduces both wind and water erosion.

Grading, Erosion, and Sediment Control (GESC) Drawings: Illustrative portion of the GESC Plan that shows the location and extent of all grading, erosion, and sediment control BMPs as well as other associated information required by the GESC Manual.

Grading, Erosion, and Sediment Control (GESC) Inspector (Inspector): A SEMSWA representative who visits construction sites to check for compliance with the GESC Permit.

Grading, Erosion, and Sediment Control (GESC) Manager: On-site representative who serves as the Permittee(s) contact person with the Inspector and who is responsible for ongoing compliance with the GESC Permit.

Grading, Erosion, and Sediment Control (GESC) Permit: Permit obtained from SEMSWA prior to commencement of land disturbing activities as described in the GESC Manual.

Grading, Erosion, and Sediment Control (GESC) Plan: Plan submitted to SEMSWA for review and acceptance including GESC Drawings and the GESC Drawing and Report Checklist.

Grading, Erosion, and Sediment Control (GESC) Report: Report required to be submitted with the GESC Plan that details all aspects of the GESC Plan such as soils, areas, and volumes, etc.

Grout Mixing Stations (GMS): Contained area to isolate grout and/or mixing operations. A GMS shall be provided when masonry work is performed.

Hold Harmless Letter: Must be submitted if applicant wishes to obtain a GESC permit before the Construction Drawings are approved. The project must have received favorable recommendation from the Planning Commission or City Council. A letter acknowledging that the applicant is proceeding at their own risk and that there may be revisions that the applicant is required to implement after construction begins.**Illicit Discharge:** Any prohibited direct or indirect non-stormwater discharge into the MS4.

Inlet Protection (IP): Reinforced rock berm placed in front of (but not blocking) a curb-opening inlet, or around an area inlet to reduce sediment in runoff entering the inlet.

Insert Slope Intercept Ditch (SID): Small earth channel with accompanying earthen berm cut in on the contour used to check stormwater surface flows from leaving a construction site and to prevent run-on of stormwater surface flows from undisturbed areas contiguous with the construction site.

Land Disturbing Activity: Any activity that results in a change in the existing land surface (both vegetative and non-vegetative). Land disturbing activities include, but are not limited to clearing, grading, excavation, demolition, installation of new or improved haul roads and access roads, staging areas, stockpiling of fill materials, and borrow areas. Compaction that is associated with stabilization of structures and road construction shall also be considered a land disturbing activity.

Larger Common Plan of Development or Sale: A contiguous area where multiple separate and distinct construction activities may be taking place at different times on different schedules, but remain related. The State has determined that “contiguous” means construction activities located in close proximity to each other (within ¼ mile).

Limits of Construction: Area shown in the GESC Plan that delineates areas in which construction activities can take place including staging, storage, and stockpiling, and land disturbing activities

Major Modifications: Modifications to the GESC plan involving re-engineering, or changes to the site hydrology, which may include changes to grading, drainage, design intent, beyond limits of a Control Measure, or eliminating a Control Measure. Control Measures that may meet Major Modification requirements are indicated with a “box” on the Legend in Appendix G.

Minor Modifications: Modifications to the GESC plan made throughout the project to address changes in site conditions that do not meet the Major Modifications definition and are generally a like for like, or more suitable Control Measure substitution.

Municipal Separate Storm Sewer System (MS4): State, city, town or other public entity-owned conveyance or system of conveyances (including roads with drainage systems, municipal streets, catch basins, curbs, gutters, ditches, man-made channels, or storm drains) designed to collect or convey stormwater.

Notice of Violation (NOV): A written notice provided by a GESC Inspector if a site is found to be in non-compliance with the GESC requirements. Violations must be remedied within 48 hours, or a Stop Work Order may be issued.

Permittee(s): Owner and Contractor that obtain a GESC Permit.

Reinforced Rock Berm (RRB): Linear mass of gravel enclosed in wire mesh to form a porous filter, able to withstand overtopping. The berm is heavy and stable and promotes sediment deposition on its upstream side as well as reducing flow velocities.

Sediment Basin (SB): An impoundment that captures sediment-laden runoff and releases it slowly, providing prolonged settling times to capture coarse and fine-grain sediment.

Sediment Control Log (SCL): Cylindrical bundle of excelsior, straw, or coconut designed to form a semi-porous filter, able to withstand overtopping, and promote sediment deposition on the upstream side and reducing flow velocities.

Sediment Trap (ST): Riprap berm with a small upstream basin that acts to trap coarse sediment particles.

Seeding and Mulching (SM): Consists of drill seeding disturbed areas with permanent grasses and mechanical crimping of straw mulch to provide immediate protection against raindrop and wind erosion and, as the grass cover becomes established, to provide long-term stabilization of exposed soils.

Silt Fence (SF): Temporary sediment barrier constructed of woven fabric stretched across supporting posts. The bottom edge of the fabric is placed in an anchor trench that is backfilled with compacted soil.

Stabilized Staging Area (SSA): Refers to stripping topsoil and spreading a layer of granular material in the area to be used for a trailer, parking, storage, unloading, and loading. A stabilized staging area reduces the likelihood that the vehicles most frequently entering a site are going to come in contact with soil disturbance.

Stop Work Order: A written notice provided by a GESC Inspector that revokes a GESC Permit as a result of a priority violation; Contractors receiving a Stop Work Order shall cease construction operations until the problem is addressed and a signed Stop Work Order Release Form is obtained.

Stormwater: Runoff generated from a precipitation event.

Stormwater Construction Permit: CDPS permit issued by the Water Quality Control Division to discharge stormwater associated with construction activities into waters of the state of Colorado.

Street Sweeping (SS): Consists of cleaning mud and other debris which is tracked onto impervious surface at a construction site. Street sweeping shall be used for incidental tracking and is not intended to be used as the sole BMP.

Public Improvement Agreement (PIA): Obligates the developer/owner to install the public facilities per the approved plans and fulfill any additional requirements specific to the site.

Surface Roughening (SR): Consists of creating a series of grooves or furrow on the contour in all disturbed, graded areas to trap rainfall and reduce the formation of rill and gully erosion.

Temporary Slope Drain (TSD): A small culvert or plastic lined channel to convey runoff down a slope or channel bank to reduce the occurrence of a rill and gully erosion.

Temporary Stream Crossing (TSC): A rock layer placed temporarily in a stream to allow construction equipment to cross. A stream crossing may include culverts or provide a low-water crossing, or ford.

Variance: A formal request made to SEMSWA by the Permittee to modify or alter existing engineering standards for a specific project

Vehicle Tracking Control (VTC): Pad of rock at all exit points for a site that is intended to help strip mud from tires prior to vehicles leaving the construction site.

Waters of the State (of Colorado): Any and all surface waters and subsurface waters which are contained in or flow in or through this state, but does not include waters in sewage systems, waters in treatment works of disposal systems, waters in potable water distribution systems, and all water withdrawn for use until use and treatment have been completed. This definition can include water courses that are usually dry.